



# RADIO TRANSMISSION MODULE SM7



## USER'S MANUAL





# **RADIO TRANSMISSION MODULE**

## **SM7**

---

### **USER'S MANUAL**

#### **CONTENTS**

<b>1. APPLICATION.....</b>	<b>5</b>
<b>2. SET OF THE SM7 MODULE.....</b>	<b>6</b>
<b>3. INSTALLATION .....</b>	<b>6</b>
3.1. Module Mounting.....	7
3.2. SM7 Electrical Connections .....	8
3.3. Way of Connection with Devices .....	10
3.4. Requirements for Outlet Connections .....	11
3.5. Examples of LUMEL-Heat, LUMEL-Energy and LUMEL 3000 Configurations to Co-operate with SM7 Module.....	11
<b>4. MODULE PRINCIPLE OF OPERATION.....</b>	<b>12</b>
4.1. First Start of the SM7 Module and PC Computer.....	14
4.1.1. <i>Installation of the Configuration Program on PC</i> .....	14
4.1.2. <i>Configuration Procedure of the SM7 Module</i> .....	14
<b>5. TECHNICAL DATA.....</b>	<b>20</b>
<b>6. SM7 ORDER CODES.....</b>	<b>22</b>
<b>7. MAINTENANCE AND WARRANTY .....</b>	<b>22</b>



## 1. APPLICATION

The SM7 radio transmission module is a device destined for data transmission by radio in the non-licensed 433 MHz or 868 MHz band with output power from -20 to 10 dBm in one of ten accessible radio channels. The data baud rate in the radio channel changes in the range: 4800.....76800 bit/s, however in the serial port, it is possible to set up the baud rate in the range: 4800.....115200 bits/s.

These changes are carried out by means of the annexed SM7Config.exe configuration program.

The offered module is become completed with a stub antenna equipped with a connector of SMA type, SMA/SMA angle adapter and a concentric cable destined to locate the antenna in any place.

The SM7 radio transmission module finds application among other things in power engineering, automatics - for monitoring data of the manufacturing process and in many other applications requiring data transmission.

The SM7 module enables the data readout from devices equipped with serial interfaces (RS-485 or RS-232). The data exchange with the master device is carried out in the radio circuit with 433 MHz or 868 MHz frequency.

The SM7 module enables the work in one of ten radio channels, in two different types of data encoding, Manchester or NRZ.

The addressing radio circuit has been applied in the module, what gives the possibility of grouping modules working on the same radio channel.

Exemplary applications of the SM7 module are presented on the fig. 1.

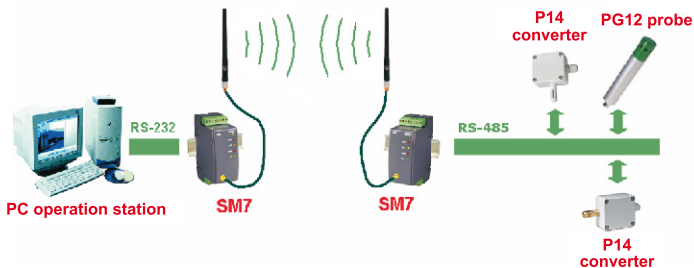

**Fig.1. Exemplary monitoring of temperature, humidity and pressure**

## 2. SET of the SM7 MODULE

The set of the data acquisition module is composed of:

- SM7 module ..... 1 pc,
- stub antenna..... 1 pc,
- SMA/SMA angle adapter ..... 1 pc,
- antenna cable ..... 1 pc,
- plug with screw terminals of BU1005 type .....2 pcs,
- plug with screw terminals of BU0204 type .....2 pcs,
- SM7 user's manual..... 1 pc,
- warranty card..... 1 pc,
- mini CD with software ..... 1 pc.

When unpacking the instrument, please check whether the type and execution code on the data plate correspond to the order.

## 3. INSTALLATION and SAFETY REQUIREMENTS

Symbols located in this service manual mean:



### **WARNING!**

Warning of potential, hazardous situations.

Especially important. One must acquaint with this before connecting the instrument. The non-observance of notices marked by these symbols **can occasion severe injuries of the personnel and the damage of the instrument!**



### **CAUTION!**

Designates a general useful note. If you observe it, handling of the meter is made easier. One must take note of this, when the instrument is working inconsistently to the expectations. **Possible consequences if disregarded !**

In the security scope the instrument meets the requirements of the EN 61010 -1 standard.

### **Remarks concerning the operator safety:**

#### **1. General**

- The instrument is destined to be mounted on a 35 mm rail acc. to the fig. 2.
- Non-authorized removal of the required housing, inappropriate use, incorrect installation or operation create the risk of injury to personnel or damage to

equipment. For more detailed information, please study the present user's manual.

- All operations concerning transport, installation, and commissioning as well as maintenance must be carried out by qualified, skilled personnel and national regulations for the prevention of accidents must be observed.
- According to this basic safety information, qualified, skilled personnel are persons who are familiar with the installation, assembly, commissioning, and operation of the product and who have qualifications necessary for their occupation.

## **2. Transport, storage**

Please observe the notes on transport, storage and appropriate handling.

Observe the climatic conditions given in Technical Data.

## **3. Installation**

- The meter must be installed according to the regulation and instructions given in this user's manual.
- Ensure proper handling and avoid mechanical stress.
- Do not bend any components and do not change any insulation distances.
- Do not touch any electronic components and contacts.
- Instruments may contain electrostatically sensitive components, which can easily be damaged by inappropriate handling.
- Do not damage or destroy any electrical components since this might endanger your health!

## **4. Electrical connection**

- Before switching the instrument on, one must check the correctness of connection to the network.
- In case of the protection terminal connection with a separate lead one must remember to connect it before the connection of the instrument to the mains.
- When working on live instruments, the applicable national regulations for the prevention of accidents must be observed.
- The electrical installation must be carried out according to the appropriate regulations (cable cross-sections, fuses, PE connection). Additional information can be obtained from the user's manual.
- The documentation contains information about installation in compliance with EMC (shielding, grounding, filters and cables). These notes must be observed for all CE-marked products.
- The manufacturer of the measuring system or installed devices is responsible for the compliance with the required limit values demanded by the EMC legislation.

## **5. Operation**

- Measuring systems including SM7 modules must be equipped with protection devices according to the corresponding standard and regulations for prevention of accidents.
- After the instrument has been disconnected from the supply voltage, live components and power connections must not be touched immediately because capacitors can be charged.
- The housing must be closed during operation.

## **6. Maintenance and servicing**

Please observe the manufacturer's documentation.

Read all product-specific safety and application notes in this user's manual.

- Before taking the meter housing out, one must turn the supply off.
- The removal of the instrument housing during the warranty contract period may cause its cancellation.

### **3.1. Module mounting**

The module is fixed on a 35 mm rail acc. to the fig.2.

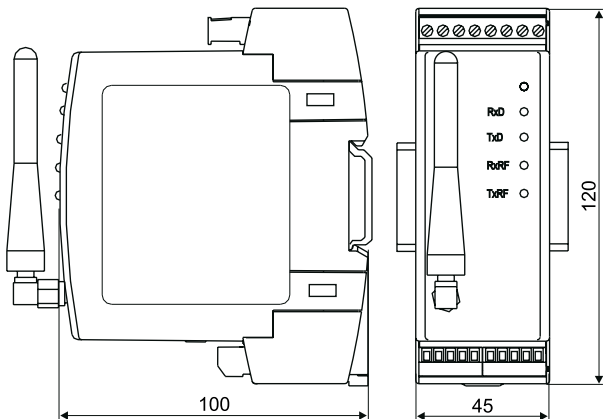
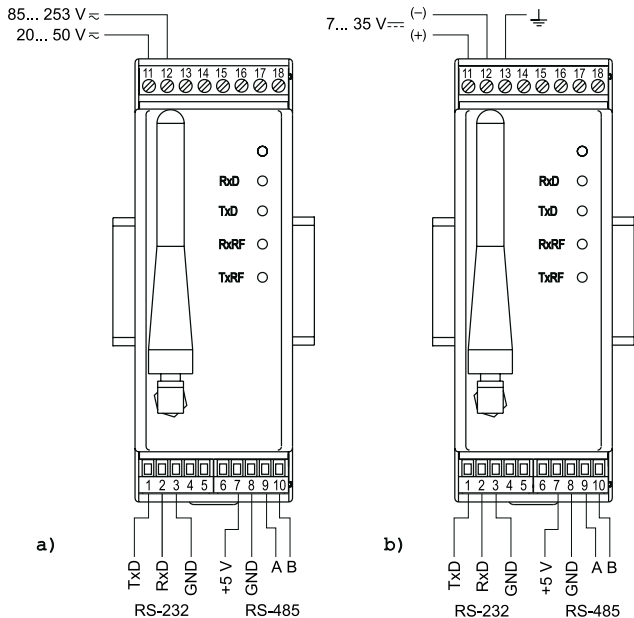

**Fig.2. Overall dimensions and module fixing way**



## 3.2. SM7 Electrical Connections

The supply and external signals must be connected acc. to the fig. 3 and the table 1 in which the assignment of particular outlets of the SM7 module has been described.



a) for 85...253 V a.c./d.c. and 20...50 V a.c./d.c. supplies

b) for 7...35 V d.c. supply

**Fig. 3. Description of SM7 outlets**

**Description of SM7 outlets**

Table 1

<b>Terminal No</b>	<b>Terminal description</b>
1	TxD RS-232 line
2	RxD RS-232 line
3	GND RS-232 line
4	(not used)
5	(not used)
6	(not used)
7	+5 V 25 mA line
8	GND RS-485 line
9	A RS-485 line
10	B RS-485 line
11	Supply line (+ for d.c. current supply)
12	Supply line (- for d.c. current supply)
13	Functional ground line (d.c. supplied)
14	(not used)
15	(not used)
16	(not used)
17	(not used)
18	(not used)

**Description of SM7 module diodes**

Table 2

<b>Markings</b>	<b>Description</b>
RxD (red)	Data receipt from the serial port
TxD (yellow)	Data transmission to the serial port
RxRF (red)	Receipt of radio data
TxRF (green)	Transmission of radio data

### 3.3. Way of Connection with Devices

The way of SM7 module connection to RS-232 or RS-485 interfaces are presented on fig. 4 and 5.

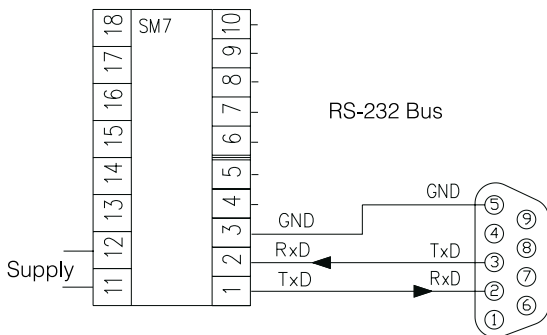

**Fig.4** Connection way of SM7 module to the RS-232 bus

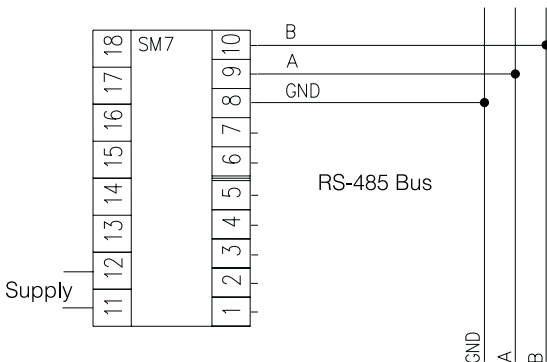

**Fig.5** Connection way of SM7 module to the RS-485 bus

**Caution:**



Considering electromagnetic interference, one must apply shielded wires to connect RS-485 interface signals. The shield must be connected to the earth terminal in a single point. The supply should be connected to the earth terminal in a single point. The supply should be connected by a two-wire cable, with an appropriate diameter of wires assuring its protection by means of an installation cut-out.

### 3.4. Requirements for Outlet Connections



Practically, different interference sources occurring, influence on the module in a continuous or impulse way from the supply network side (in consequence of the other device operations). The level of this interference should be reduced to a value lower than the module immunity threshold, first of all through the appropriate module installation in the object.

**In order to obtain a full immunity of the module against electromagnetic interference in an environment with an unknown interference level, it is recommended to observe following principles:**



- Do not apply the module from the network in the proximity of devices generating high impulse interference,
- Apply network filters for the group of modules servicing the same object,
- Apply the general principles, that wires (group of wires) leading different signals should be led farther away to one another (not less than 50 cm), and crossings of such group of wires made at an 90° angle.

### 3.5. Example of Lumel Heat, Lumel Energy and Lumel 3000 Configuration to Co-operate with the SM7 Module

Lumel Heat and Lumel 3000 systems communicate with industrial devices by means of COM serial ports. The SM7 module does not require the installation of whatever programmable logic controller.

In case when there is not enough of serial ports in the computer, one can increase this number installing a PD10 or PD12 USB converter on the bus, what extends computer resources with additional COM ports. After installing additional COM serial ports, one can refer to them in systems of Lumel series. Then, one must introduce or change supervisory calls to the added communication ports, in new or existing applications or system configurations.

Lumel Energy softwares in older version then 2.5, service maximally 4 serial ports, and they must be installed as COM 1...4 in such systems.

## 4. SM7 MODULES PRINCIPLE OF OPERATION

The SM7 radio transmission module enables the radio communication of devices equipped with an RS-232 or RS-485 serial port.

The maximal baud rate in the radio channel is 76800 bit/s. This rate can be changed in the range: 4800....76800 bit/s.

The communication with RS-232 or RS-485 interfaces can be carried out with baud rates from 4800... 115200 bit/s. The radio transmission is performed maximally in the shape of 226 byte packages, from which 256 bytes are data received from the serial port, and remaining are applied for the need of package forming.

The data transmission is carried out in the following way: data bits are received from the serial port and they are switched over to the sending buffer. If the sending buffer will be filled up or if a suitable time is elapsed („time out”), data are placed in a frame automatically provided with an appropriate heading and transmitted by the radio channel.

The heading is built from the sequence of six unique bytes, allowing the receiving devices to identify streams of radio waves as frames with data. Apart from the cited sequence of bytes, the group address of the module transmitting data is encoded in the frame heading.

The insertion of this address in the frame increases the data safety and allows to create several groups of modules working independently on the same radio channel.

The reception of radio data resolves itself into the detection of the correct data frame. After receiving the correct frame, the grouped address encoded in the frame is checked. If the address is identical as the module address, which the frame have received, then received data are directed to the serial port.

The current operating conditions of the module are signalled by lighting diodes:

Red RxD diode and yellow TxD diode signal the data flow through the serial port, however the red RxRF and green TxRF signal the data flow through the radio channel. If during the transmission both the red RxRF diode and the green TxRF diode are lighted, that means that the reception buffer was overfilled by a too high number of data from the serial port (more than 256 characters) and their transmission through the radio line was cancelled. RxRF and TxRF diodes are also lighted after introducing the module in the configuration state.

The transmission between the master device and the module can run faster than in the radio circuit because of the RS-485 port application to control the data flow, the CTS signal which informs the master device if the module is ready to the data reception, has not been applied. In this connexion, for the correct module operation, it is recommended to apply the same baud rates of the serial port and the radio circuit.

The module is configured by the manufacturer to work on the serial port with a 9600 bit/s baud rate in the 8N2 mode, and on the radio circuit with the 9600 bit/s baud rate,

with the Manchester encoding and the transmitter power equal + 10 dBm, however all parameters can be changed depending on requirements.

The configuration is carried out by means of the SM7config.exe configuration program. The configuration program takes advantage of the RS-232 serial port and exchanges data with the SM7 module using its own communication protocol.

One must remember, that the module configuration program works with following serial port settings:

- baud rate: 9600 bit/s
- transmission mode: 8N2

To switch the SM7 module into the configuration mode, one must press for three seconds during the module operation, the button being at the bottom of the housing. The button location is presented on the fig.6.

After pressing the button, the SM7 module breaks the normal operation, switches over to the configuration mode and adapts the setting of its serial port to settings of the configuration program, i.e. 9600, 8N2

After the configuration change, one must turn the module supply off, and next switch it on again. The module will start to the normal work with new settings.

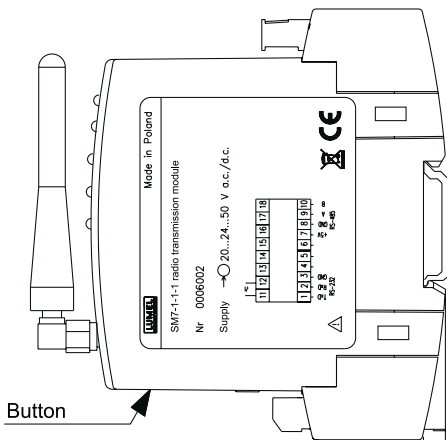

**Fig.6. Location of the configuration button**

## **4.1. First Start of the SM7 Module**

At the first start, the SM7 module requires settings of following indispensable information: group address, radio channel, transmitter power, type and radio baud rate. Apart of this, it is necessary to set parameters of the serial port: baud rate and transmitter mode. The „SM7config.exe“) program added to the set, allows the user to configure in an easy way the SM7 module setting.

### **4.1.1. Installation of the Configuration on PC**

The installation consists in copying of the „SM7config.exe“ program from the added CD disk to the set, into the catalogue assigned by the user on the computer hard disk. The program can be also started directly from the CD disk.

### **4.1.2. Configuration Procedure of the SM7 Module**

In order to configure the SM7 module, one must connect it to the computer serial port:

RS-232 (outlet description according to the fig. 3.), next, turn the module supply on, press the module configuration button and hold it during ca 1 sec. Then, RxRF and TxRF diodes are lighting till the moment of the supply turning off. After starting the „SM7Config.exe“ program, one can choose in the „Port COM:“ field, the number of the COM port which the SM7 module is connected to. After pressing the „Connect“ button, the configuration program establishes the connection with the SM7 module, and the message: „Connected with the COM port“ appears in the communication window.

In case of access lack to the COM port, the information about the lack of connection with the COM port will be displayed in the message window. After the correct connection established with the SM7 module, the configuration program displays the information about the current module configuration.

The change of the module configuration consists in making the choice in appropriate fields in the program window.

Following options are accessible:

- Options of the serial port.
  - serial baud rate (4800....115.200 bit/s),
  - serial transmission mode (8N1, 8N2, 8E1, 8O1, 7E1, 7O1).
- Options of the radio port:
  - setting of the radio circuit ( group address, radio channel number),
  - transmission type (baud rate: 4800....76800 bit/s and encoding type: NRZ or Manchester),
  - transmission power ( from - 20 dBm to 10 dBm).

**NOTE:** One must remember that the optimal module work is reached at the setting of similar baud rate for both interfaces, i.e. the serial port and the radio circuit. For other settings, the occurrence of erroneous data transmission states is possible.



The button „Restore manufacturer settings” allows to set up manufacturer settings in the module.

Each change of settings is registered in the message window of SM7Config.exe program and transmitted to the SM7 module.

In case of correctly or erroneously carried out operation of the setting change, an appropriate message will be displayed in the message window

After carrying out changes, one must disconnect the transmission choosing the „Disconnect” button. The disconnection of the transmission and the release of the COM port by SM7Config.exe will follow. Set parameters of the module configuration will be operative after turning the module supply off for ca 3 sec. and it renewed turning on.

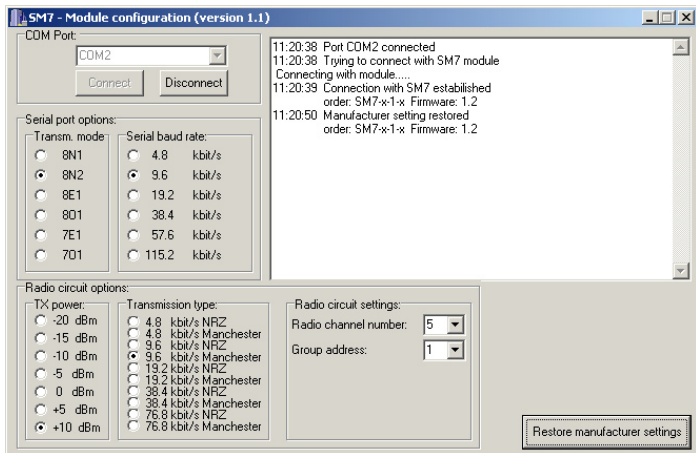

**Fig. 7. View of the SM7Conf.exe configuration application**



## 5. TECHNICAL DATA

### Port 1:

- RS-232 interface
  - data format 8N1, 8N2, 8E1, 8O1, 7E1, 7O1
  - baud rate 2400... 115200 bit/s

### Port 2:

- RS-485 interface
  - format danych 8N1, 8N2, 8E1, 8O1, 7E1, 7O1
  - prędkość transmisji 4800... 115200 bit/s

### Radio circuit:

- carrier frequency 433, 868 MHz
- power -20, -15, -10, -5, 0, 5;  
(10 dBm only for 433 MHz)
- receiver sensitivity -110 dBm
- baud rate 4800, 9600, 19200, 38400, 76800 bit/s
- encoding type NRZ, Manchester
- transmission range in direct line 300 m
- number of channels 10
- antenna output 50 Ω SMA

### Time of availability obtainment since the supply connection

2 s

### Module input power

≤ 2.5 VA

### Rated operating conditions:

- supply voltage 7... 35 V d.c.; 20... 24...50 V a.c./d.c.  
85...230... 253 V a.c./d.c.
- ambient temperature 0...23...45°C
- relative air humidity < 95% (condensation inadmissible)
- service position any

### Storage and handling conditions:

- ambient temperature -20... 70°C
- relative air humidity < 95% (condensation inadmissible)

### Ensured protection grade:

- from the housing side IP 20
- from the terminal side IP 20

### Overall dimensions

45 × 120 × 100 mm

### Weight

0.5 kg

**Housing**

for 35 mm rail mounting,  
acc. EN 60715

**Electromagnetic compatibility:**

- noise immunity acc. EN 61000-6-2
- resistance against supply decay acc. EN 61000-6-2
- noise emissions acc. EN 61000-6-4

**Safety requirements acc. to EN 61010-1:**

- installation category III
- pollution grade 2
- maximal phase-to-earth work voltage:
  - for supply circuit 50 V
  - for other circuits 50 V

**SM7 ORDER CODES**

Radio transmission module SM7	X	X	X
<b>Supply voltage:</b>			
85... <u>230</u> ...253 V a.c./d.c.....	1		
20... <u>24</u> ...50 V a.c./d.c.....	2		
7...35 V d.c. ....	3		
on order* .....	X		
<b>Radio carrier frequency:</b>			
433 MHz .....	1		
868 MHz .....	2		
<b>Acceptance tests:</b>			
without additional tests .....	8		
with an extra quality inspection certificate .....	7		
acc.to user's agreement* .....	X		

\* The manufacturer will establish the code number.

**Coding example:**

The **SM7 1 2 7** code number means:

**SM7** - Radio transmission module

1 - supply voltage: 85...230...253 V a.c./d.c.

2 - radio carrier frequency: 868 MHz

7 - with an extra quality inspection certificate

## 7. MAINTENANCE AND WARRANTY

The SM7 modul does not require any periodical maintenance.

In case of some incorrect operations:

### 1. After the dispatch date and within the period stated in the warranty card

One should return the instrument to the LUMEL's Quality Inspection Dept.

If the instrument has been used in compliance with the user's manual, LUMEL S.A. warrants to repair it free of charge. The disassembling of the housing causes the cancellation of the granted warranty.

### 2. After the warranty period:

One should send the instrument to repair it in a authorized service workshop. Spare parts are available for the period of five years from the date of purchase.

**LUMEL S.A. reserves the right to make changes in design and specifications of any products as engineering advances or necessity**

## **SALES PROGRAM**

- DIGITAL and BARGRAPH PANEL METERS
- MEASURING TRANSDUCERS
- ANALOG PANEL METERS (DIN INSTRUMENTS)
- ANALOG and DIGITAL CLAMP-ON METERS
- INDUSTRIAL and HOUSEHOLD CONTROLLERS
- CHART AND PAPERLESS RECORDERS
- POWER CONTROL UNITS and INVERTERS
- LARGE SIZE NUMERIC and ALPHANUMERIC DISPLAYS
- AUTOMOTIVE DASHBOARD INDICATORS
- ACCESSORIES FOR MEASURING INSTRUMENTS
- MEASURING SYSTEMS (ENERGY, HEAT, CONTROL)
- CUSTOM-MADE PRODUCTS

***MEASUREMENT  
CONTROL  
RECORDING***

## **WE ALSO OFFER OUR SERVICES IN THE PRODUCTION OF:**

- ALUMINIUM ALLOY PRESSURE CASTINGS
- PRECISION ENGINEERING AND THERMOPLASTICS PARTS
- PRESSURE CASTING DIES AND OTHER TOOLS

## **QUALITY PROCEDURES:**

According to ISO 9001 and ISO 14001 international requirements.

All our instruments have CE mark .

For more information, please write to or phone our Export Department



**Lubuskie Zakłady Aparatów Elektrycznych LUMEL S.A.**  
ul. Sulechowska 1, 65-022 Zielona Góra, Poland

Tel.: (48-68) 329 51 00 (exchange)

Fax: (48-68) 329 51 01

e-mail: [lumel@lumel.com.pl](mailto:lumel@lumel.com.pl)

<http://www.lumel.com.pl>

### **Export Department:**

Tel.: (48-68) 329 53 02 or 53 04

Fax: (48-68) 325 40 91

e-mail: [export@lumel.com.pl](mailto:export@lumel.com.pl)