

LUMEL

**MODULE
WITH 8 LOGIC
INPUTS
SM5 TYPE**



USER'S MANUAL

CE

CONTENTS

1. APPLICATION.....	5
2. MODULE SET	5
3. BASIC REQUIREMENTS AND OPERATIONAL SAFETY.....	6
4. INSTALLATION.....	8
4.1. Module fixing	8
4.2. Electrical connections.....	8
5. SERVICE.....	11
5.1 Description of the MODBUS protocol implementation	11
5.2 Description of the MODBUS protocol functions	12
5.3. Map of module registers.....	15
5.4. Set of module registers	16
6. TECHNICAL DATA	20
7. BEFORE A DAMAGE WILL BE DECLARED	21
8. ORDERING CODES	22
9. MAINTENANCE AND GUARANTEE	23

1. APPLICATION

The SM5 module has 8 logic inputs and RS-485 and RS-232 interfaces with MODBUS RTU and ASCII transmission protocols.

It is destined to readout logic states of logic inputs and enables their access in industrial systems. Ports in RS-485 and RS-232 are galvanically isolated from input signals and the supply. The module programming is possible by means of the RS-485 or the RS-232 port. Configurable baud rate: 2400, 4800, 9600, 19200, 38400, 57600, 115200 bit/s. The SM5 module set includes a connecting cable to connect with the PC computer (RS-232).

2. MODULE SET

The set consists of:

- SM5 module 1 pc.
- user's manual 1 pc.
- guarantee card 1 pc.
- plug with BU1005 screw terminals 2 pcs
- plug with BU0204 screw terminals 2 pcs
- RS-232 socket hole plug 1 pc
- RS-232 wire to connect with the computer (1.5 m.) 1 pc

When unpacking the module, please check whether the type and version code on the data plate correspond to the order.

3. BASIC REQUIREMENTS, SAFETY INFORMATION

Symbols located in this service manual mean:

WARNING!



Warning of potential, hazardous situations. Especially important, one must acquaint with this before connecting the module. The non-observance of notices marked by these symbols can occasion severe injuries of the personnel and the damage of the module.

CAUTION!



Designates a general useful note. If you observe it, handling of the module is made easier. One must take note of this, when the module is working inconsistently to the expectations. **Possible consequences if disregarded !**

In the security scope the module the requirements of the EEC. Low-Voltage Directive (EN 61010 -1 issued by CENELEC).

Remarks concerning the operator safety:



1. General

- The SM5 module is destined to be installed in measuring systems, on a 35 mm mounting rail
- Non-authorized removal of the required housing, inappropriate use, incorrect installation or operation creates the risk of injury to personnel or damage to equipment. For more detailed information please study the user's manual.
- All operations concerning transport, installation, and commissioning as well as maintenance must be carried out by qualified, skilled personnel and national regulations for the prevention of accidents must be observed.
- According to this basic safety information, qualified, skilled personnel are persons who are familiar with the installation, assembly, commissioning, and operation of the product and who have qualifications necessary for their occupation.

2. Transport, storage

Please observe the notes on transport, storage and appropriate handling.

Observe the climatic conditions given in technical data.

3. Installation

- The module must be installed according to the regulation and instructions given in this user's manual.
- Ensure proper handling and avoid mechanical stress.
- Do not bend any components and do not change any insulation distances.

- Do not touch any electronic components and contacts.
- Modules may contain electrostatically sensitive components, which can easily be damaged by inappropriate handling.
- Do not damage or destroy any electrical components since this might endanger your health!

4. Electrical connection

- Before switching the module on, one must check the correctness of connection to the network.
- In case of the protection terminal connection with a separate lead, one must remember to connect it before the connection of the module to the mains.
- When working on live modules, the applicable national regulations for the prevention of accidents must be observed.
- The electrical installation must be carried out according to the appropriate regulations (cable cross-sections, fuses, PE connection). Additional information can be obtained from the user's manual.
- The documentation contains information about installation in compliance with EMC (shielding, grounding, filters and cables). These notes must be observed for all CE-marked products.
- The manufacturer of the measuring system or installed devices is responsible for the compliance with the required limit values demanded by the EMC legislation.

5. Operation

- Measuring systems including SM5 modules must be equipped with protection devices according to the corresponding standard and regulations for prevention of accidents.
- After the instrument has been disconnected from the supply voltage, live components and power connections must not be touched immediately because capacitors can be charged.
- The housing must be closed during operation.
- The RS-232 socket serves only to connect the device (Fig. 2) working with the MODBUS protocol. When the module is not used, place the hole plug in the RS-232 socket of the module.

6. Maintenance and servicing

Please observe the manufacturer's documentation.

Read all product-specific safety and application notes in this user's manual.

- Before taking the module out, one must turn the supply off.
- The removal of the module housing during the guarantee period may cause its cancellation.

4. INSTALLATION

4.1 Module fixing

The SM5 module is fixed on a 35 mm rail in accordance with EN 60715. The module housing is made of a self-extinguishing plastic. Overall dimensions of the housing: 45 x 120 x 98 mm.

Overall dimensions and the fixing way are presented on the fig. 1.

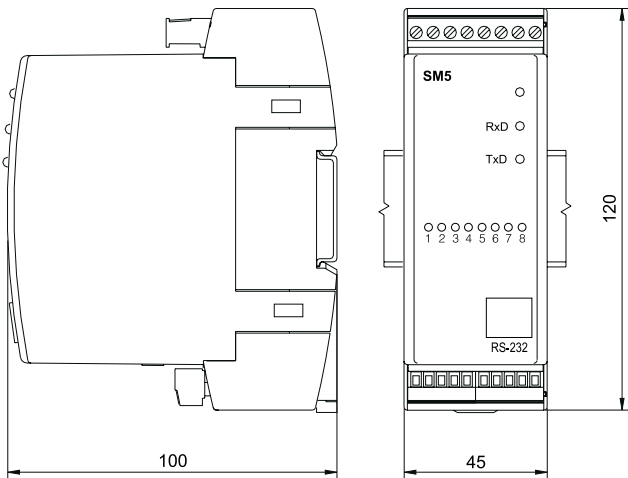

Fig.1. Overall dimensions and way of the module fixing

4.2. Electrical connections

Following external wires can be connected to the module:

- up to 2.5 mm² cross-section (from supply and interface side),
- up to 1.5 mm² cross-section (from input signal side).

Caution:

One must pay special attention to the correct connection of external signals (see fig. 2)



Caution:

Regarding electromagnetic interference one must use shielded wires to connect binary input signals and RS-485 interface signals. The shield must be connected to the protective terminal in one point.

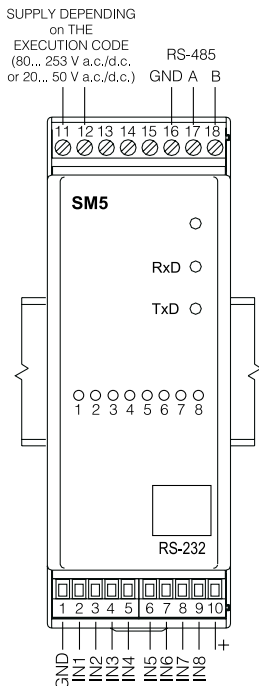

Fig 2. Electrical connections of SM5 logic input module

There are three diodes on the frontal plate:

- **green** - signals switching the supply on
- **green (Rx D)** - signals data reception through the module
- **yellow (Tx D)** - signals data transmission through the module

The „+” signal (terminal 10) is the 5 V output with admissible overload 100 A. One must connect binary signals to the mass and appropriate output terminal.

The way to connect interfaces are shown on fig. 3 and 4. To obtain a correct transmission through the RS-485 interface it is necessary to connect lines A and B lines in parallel with their equivalents in other devices. The connection must be made with a shielded wire. The shield must be connected to a shielded wire. The shield must be connected to the protective terminal, in one point.

The **GND** line serves to equalize potentials of interface lines in the communicating devices.

To obtain the communication with the computer of PC class through the RS-485 port, it is essential to apply an RS-232/RS-485 converter (e.g. PD51 from Lumel production) or an RS-485 interface card. Marking of transmission lines for the card in the PC computer depends on the card producer.

To obtain the connection through the RS-232 port, the added wire in the module set, is sufficient.

The module can be connected to a device of master type through one interface port. In case of the simultaneous connection of both ports, the module will work through the RS-232 interface

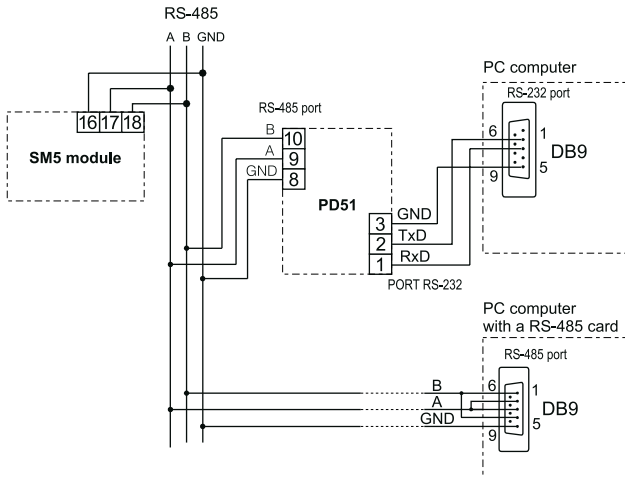

Fig. 3 Way of the RS-485 interface connection.

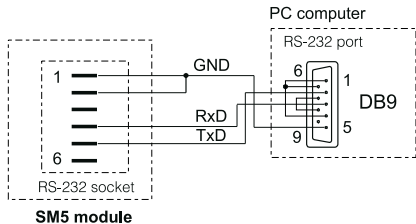

Fig. 4 Way of the RS-232 interface connection.

5. SERVICE

After connecting external signals and switching the supply on, the SM5 module is ready to work.

The lighted green diode signals the module work. The green diode (RxD) signals the module polling, however the yellow diode (TxD) signals the module response. Diodes should ignite in cycles during the data transmission, through the RS-232 or the RS-485 interface. Programmable parameters of the module can be programmed by means of RS-232 or RS-485 ports.

The RS-232 port has constant transmission parameters acc. to technical data, what enables the connection to the module even when programmed parameters of the digital RS-485 output (address, mode, rate) are unknown

The RS-485 standard allows to the direct connection to 32 devices on a single serial link up to 1200 m. To connect a greater number of devices it is necessary to use additional intermediate-separating systems (e.g. the PD51 converter/repeater).

5.1. Description of MODBUS protocol implementation

The transmission protocol describes ways of the information exchange between devices through serial links.

The MODBUS protocol has been implemented in the module in accordance with the PI-MBUS-300 Rev G specification of the Modicon company.

Set of parameters of the module serial link in the MODBUS protocol:

- module address - 1... 247
- baud rate - 2400, 4800, 9600, 19200, 38400, 57600, 115200 bit/s
- working modes - ASCII, RTU

- information unit - ASCII: 8N1, 7E1, 7O1
- RTU: 8N2, 8E1, 8O1, 8N1
- maximal response time - 300 ms.

The parameter configuration of the serial link is described in the further part of the user's manual. It consists on establishing the baud rate (**baud** parameter), device address (**Adr** parameter) and the information unit type (**Mode** parameter).

In case of the module connection with the computer through the RS-232 wire, the module set automatically following transmission parameters:

Baud rate: 9600 bps,

Working mode: RTU 8N1,

Address: 1.

Notice: Each module connected to the communication network must:

- have a unique address, different from addresses of other devices connected to the network,
- identical baud rate and information unit type,
- the message sent with the address „0” is identified as the data transmission mode (transmission to many devices).

5.2. Description of the MODBUS protocol function

Following functions of the MODBUS protocol have been implemented in the SM5 module.

Description of MODBUS protocol functions Table 2

Code	Signification
02 (02h)	Readout of n-bit registers
03 (03h)	Readout of n-register
04 (04h)	Write of n-input registers
06 (06h)	Write of a single register
16 (10h)	Write of n-registers
17 (11h)	Slave device identification

Readout of n-registers (code 02h)

The function is not accessible in the broadcast mode.

Example: Readout of 8 bit registers beginning by the register with the 07D0h (2000) address

Request:

Device address	Function	Register address		Number of registers		Checksum CRC
		Hi	Lo	Hi	Lo	
01	02	07	D0	00	08	7941

Answer:

Device address	Function	Number of bytes	Value from the register 2200 - 2207	Checksum CRC
01	02	01	01	6048

Readout of n-registers (code 03h)

The function is not accessible in the broadcast mode.

Example: Readout of 2 registers with 1DBDh (7613) address:

Request:

Device address	Function	Register address Hi	Register address Lo	Number of registers Hi	Number of registers Lo	Checksum CRC
01	03	1D	BD	00	02	52 43

Answer:

Device address	Function	Number of bites	Value from the register 1DBD (7613)				Value from the register 1DBE (7614)				Checksum CRC
01	03	08	3F	80	00	00	40	00	00	00	42 8B

Readout of n-input registers (code 04h)

The function is not accessible in the broadcast mode.

Example: readout of 1 register with the 0FA3h (4003) address

Request:

Device address	Function	Register address Hi	Register address Lo	Number of registers Hi	Number of registers Lo	Checksum CRC
01	04	0F	A3	00	01	C2 FC

Answer:

Device address	Function	Number of bytes	Value from the register 0FA3 (4003)		Checksum CRC
01	04	02	00	01	78 F0

Write of values in the register (code 06h)

The function is accessible in broadcast mode.

Example: Write of the register with 1DBDh (7613) address

Request:

Device address	Function	Register address		Value from the register 1DBD (7613)				Checksum CRC
		Hi	Lo					
01	06	1D	BD	3F	80	00	00	85 AD

Answer:

Device address	Function	Register address		Value from the register 1DBD (7613)				Checksum CRC
		Hi	Lo					
01	06	1D	BD	3F	80	00	00	85 AD

Write into n-registers (code 10h)

The function is accessible in the data transmission mode.

Example: Write 2 registers beginning from the register with 1DBDh (7613) address.

Request:

Device address	Function	Register address		Number of registers		Number of bytes	Value from the register 1DBD (7613)				Value from the register 1DBE (7614)				Checksum CRC
		Hi	Lo	Hi	Lo										
01	10	1D	BD	00	02	08	3F	80	00	00	40	00	00	00	03 09

Answer:

Device address	Function	Register address Hi	Register address Lo	Number of registers Hi	Number of registers Lo	Checksum (CRC)
01	10	1D	BD	00	02	D7 80

Report identifying the device (code 11h)

Request:

Device address	Function	Checksum (CRC)
01	11	C0 2C

Answer:

Device address	Function	Number of bytes	Device identifier	Device state	Software version number	Checksum
01	11	06	8D	FF	XXXX	

Device address	- depends on the set value,
Function	- function number: 0x11,
Number of bytes	- 0x08
Device identifier	- 0x8F
Device state	- 0xFF
No of the software version software	- software version implemented in the module:1.00 XXXX - 4-byte variable of float type
Checsun	- 2 bytes, in case of work in the RTU mode - 1 byte, in case of work in the ASCII mode

Example:

The work in **RTU** mode, e.g.: **Mode = RTU 8N2** (value 0x02 in case of readout/write through the interface).

Device address set on **Adr=0x01**,

For the SM5 module, the response frame has the following shape:

Device address	Function	Number of bytes	Device identifier	Device state	Number of softwer version	Checksum CRC
01	11	06	8E	FF	3F 80 00 00	AE 1B

Jest to moduł SM5, wersja oprogramowania 1.00

5.3. Register map of the module

Register map of SM5 module series

Table 2

Address range	Value type	Description
2000-2007	bool (1 bit)	The value is located in 1-bit register. Registers can be read out and written.
4000-4100	integer (16 bitów)	The value is located in 16-bit registers. The register content corresponds to the 32-bit register contents from the 7500 area. Registers are only for readout.
4200-4300	integer (16 bitów)	The value is located in 16-bit registers. The register content corresponds to the 32-bit register contents from the 7600 area. Registers can be read out and written.
7500-7600	float (32 bity)	The value is located in the 2-bit register. Registers are only for readout.
7600-7700	float (32 bity)	The value is located in the 32-bit register. Registers can be read out and written.

5.4. Set of module registers

Set of registers for readout the SM5 module

Table 3

The value is placed in 1-bytes registers. These registers content corresponds to the content of 32-bit registers from the area 7500.			The value is placed in 16-bytes registers. These registers content corresponds to the content of 32-bit registers from the area 7500.			The value is placed in 32-bytes registers.			Name	Write (w)/Readout (r)	Unit	Quantity name
	4000	7500				Identifier	0	-	Constant identifying the device			
	4001	7501				Status 1	0	-	Status 1 is a register describing current states of binary inputs.			
	4002	7502				Status 2	0	-	Status 2 is a register describing current transmission parameters.			
2000	4003	7503				W1	0	-	Value of read out state of input 1			
2001	4004	7504				W2	0	-	Value of read out state of input 2			
2002	4005	7505				W3	0	-	Value of read out state of input 3			
2003	4006	7506				W4	0	-	Value of read out state of input 4			
2004	4007	7507				W5	0	-	Value of read out state of input 5			
2005	4008	7508				W6	0	-	Value of read out state of input 6			
2006	4009	7509				W7	0	-	Value of read out state of input 7			
2007	4010	7510				W8	0	-	Value of read out state of input 8			

Description of the Status1 register

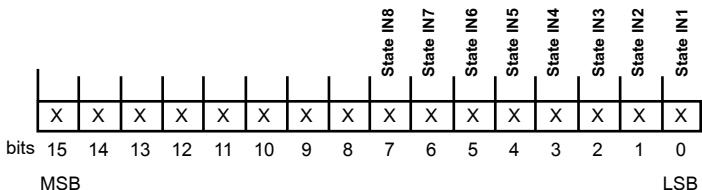

Bit-15...8 not used

State 0

Bit- 0 State of IN 1 input

0 - open

1 - shorting

Bit- 1 State of IN 2 input

0 - open

1 - shorting

Bit- 2 State of IN 3 input

0 - open

1 - shorting

Bit- 3 State of IN 4 input

0 - open

1 - shorting

Bit- 4 State of IN 5 input

0 - open

1 - shorting

Bit- 5 State of IN 6 input

0 - open

1 - shorting

Bit- 6 State of IN 7 input

0 - open

1 - shorting

Bit- 7 State of IN 8 input

0 - open

1 - shorting

Description of the Status 2 register

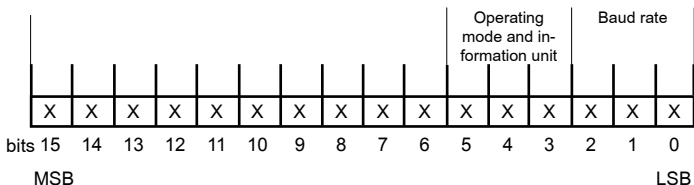

Bit-15...6 Not used

Their States are free

Bit-5...3 Operating mode and information unit

000 - interface switched off

001 - 8N1 - ASCII

010 - 7E1 - ASCII

011 - 7O1 - ASCII

100 - 8N2 - RTU

101 - 8E1 - RTU

110 - 8O1 - RTU

111 - 8N1 - RTU

Bit-2...0 Baud rate

000 - 2400 bit/s

001 - 4800 bit/s

010 - 9600 bit/s

011 - 19200 bit/s

100 - 38400 bit/s

101 - 57600 bit/s

110 - 115200 bit/s

The value is placed in 16-bytes registers. These registers content corresponds to the content of 32-bit registers from the area 7600.		The value is placed in 32-bit registers.		Symbol	Write (w)/Readout (r)	Range	Description	
4200	7600	Identifier	r	8D	Device identifier			
4201	7601	Rate	w/r	0... 6	Baud rate of the RS-485 interface (bit/s)			
							Value	
							0	2400
							1	4800
							2	9600
							3	19200
							4	38400
							5	57600
							6	115200
4202	7602	Mode	w/r	0... 7	Kind of transmission via the RS-485 interface			
							Value	
							0	Interface switched off
							1	ASCII 8N1
							2	ASCII 7E1
							3	ASCII 7O1
							4	RTU 8N2
							5	RTU 8E1
							6	RTU 8O1
							7	RTU 8N1
4203	7603	Address	w/r	1... 247	Device address			
4204	7604	Apply	w/r	0... 1	Register confirming changes of transmission parameters			

6. TECHNICAL DATA

Logic levels

1 logic: shorted input

0 logic: open input

shorting resistance of the contact without potential $\geq 10 \text{ k}\Omega$

opening resistance of the contact without potential $\geq 150 \text{ k}\Omega$

Transmission data:

a) RS-485 interface:

- transmission protocol

MODBUS

- ASCII:

8N1, 7E1, 7O1

- RTU:

8N2, 8E1, 8O1, 8N1

- baud rate:

2400, 4800, 9600, 19200,
38400, 57600, 115200 bit/s

- address:

1... 247

b) RS-232 interface:

- transmission protocol

MODBUS

- RTU:

8N1

- baud rate:

9600 bit/s

- address:

1

Power consumption by the module $\leq 1.5 \text{ VA}$

Rated operation conditions:

- supply voltage

10...24...50 V a.c./d.c.

or 85...230...253 V a.c./d.c.

- Supply voltage frequency

40...50/60...440 Hz

- ambient temperature

-20...23...55°C

- relative humidity

< 95% (inadmissible condensation)

- external magnetic field

< 400 A/m

- work position

any

Storage and transport conditions:

- ambient temperature

- 20... 70°C

- relative humidity

< 95% (inadmissible condensation)

Ensured protection grade:

- from the housing

IP 40

- from terminal side

IP 20

Dimensions	45 x 120 x 100 mm
Weight	< 0.25 kg
SM5 housing	adapted to be mounted on a 35 mm rail acc. to EN 60715

Electromagnetic compatibility:

- Immunity acc. to EN 61000-6-2
- emission acc. to EN 61000-6-4

Safety requirements acc.to EN 61010-1:

- installation category III
 - pollution grade 2
- maximal phase-to-earth work voltage:
- for the supply circuit 300 V
 - for other circuits 50 V

7. BEFORE A FAILURE WILL BE DECLARED

In case of incorrect symptoms please to acquaint with the table below.

SYMPTOMS	PROCEDURE	REMARKS
1. The green diode is off.	Check the connection of the network cable	
2. The module does not communicate with the device master via the RS-232 port. Lack of transmission signalling on RxD and TxD diodes.	Check if the wire is connected to the appropriate module socket. Check if the device master is set on 9600 baud rate, 8N1 mode and address 1.	(RS-232 has constant transmission parameters)
3. The module does not communicate with the device master via the RS-485 port. Lack of transmission signalling on RxD and TxD diodes.	Check if the wire is connected to the appropriate module terminal. Check if the device master is set on the same transmission parameters as the module (baud rate, mode, address). In case of necessity to change transmission parameters when we cannot communicate through RS-485 one can use the RS-232 port which has constant transmission parameters (in case of further problems, see the section 2). After changing e RS-485 parameters into the required one, one can switch over on RS-485 port.	

8. ORDERING CODES

Table 5

Module of 8 binary inputs - SM5	X	XX	X
Supply voltage:			
85... <u>230</u> ...253 V a.c./d.c.....	1		
20... <u>24</u> ...50 V a.c./d.c.....	2		
on order *	X		
Kind of version:			
catalogue		00	
custom -made *		XX	
Acceptance tests:			
without extra requirements			8
with an extra quality inspection certificate			7
other requirements agreed with the manufacturer*			X

* code numbering is settled by the manufacturer.

Example of order

SM5 1 00 7 code means:

- SM5** - Module of 8 binary inputs
- 1** - supply: 85...230...253 V a.c/d.c.
- 00** - catalogue version
- 7** - with an extra quality inspection certificate

9. MAINTENANCE AND GUARANTEE

The SM5 module does not require any periodical maintenance.

In case of some incorrect operations:

1. After the dispatch date and within the period stated in the guarantee card

One should return the instrument to the Manufacturer's Quality Inspection Dept. If the module has been used in compliance with the instructions, the Manufacturer guarantees to repair it free of charge. The disassembling of the housing causes the cancellation of the granted guarantee.

2. After the guarantee period:

One should send the instrument to repair it in an authorised service workshop. Spare parts are available for the period of five years from the date of purchase.

Our policy is one of continuous improvement and we reserve the right to make changes in design and specifications of any products as engineering advances or necessity requires and revise the above specifications without notice.

SALES PROGRAM

- DIGITAL and BARGRAPH PANEL METERS
- MEASURING TRANSDUCERS
- ANALOG PANEL METERS (DIN INSTRUMENTS)
- ANALOG and DIGITAL CLAMP-ON METERS
- INDUSTRIAL and HOUSEHOLD CONTROLLERS
- CHART AND PAPERLESS RECORDERS
- POWER CONTROL UNITS and INVERTERS
- LARGE SIZE NUMERIC and ALPHANUMERIC DISPLAYS
- AUTOMOTIVE DASHBOARD INDICATORS
- ACCESSORIES FOR MEASURING INSTRUMENTS
- MEASURING SYSTEMS (ENERGY, HEAT, CONTROL)
- CUSTOM-MADE PRODUCTS

**MEASUREMENT
CONTROL
RECORDING**

WE ALSO OFFER OUR SERVICES IN THE PRODUCTION OF:

- ALUMINIUM ALLOY PRESSURE CASTINGS
- PRECISION ENGINEERING AND THERMOPLASTICS PARTS
- PRESSURE CASTING DIES AND OTHER TOOLS

QUALITY PROCEDURES:

According to ISO 9001 and ISO 14001 international requirements.

All our instruments have CE mark .

For more information, please write to or phone our Export Department



Lubuskie Zakłady Aparatów Elektrycznych LUMEL S.A.
ul. Sulechowska 1, 65-022 Zielona Góra, Poland

Tel.: (48-68) 329 51 00 (exchange)

Fax: (48-68) 329 51 01

e-mail: lumel@lumel.com.pl

<http://www.lumel.com.pl>

Export Department:

Tel.: (48-68) 329 53 02 or 04

Fax: (48-68) 325 40 91

e-mail: export@lumel.com.pl