



LARGE SIZE DIGITAL DISPLAYS

DL11, DL12 and DL13 types



USER'S MANUAL



LARGE SIZE DIGITAL DISPLAYS

DL11, DL12 and DL13 types

CONTENTS:

1. APPLICATION	2
2. DISPLAY SET	2
3. BASIC REQUIREMENTS, OPERATIONAL SAFETY	2
4. DESIGN DESCRIPTION AND INSTALLATION	2
5. ELECTRICAL CONNECTIONS	4
6. CONFIGURATION OF THE DL DISPLAY	5
6.1 Configuration of the connection	6
6.2 Changing transmission parameters	6
6.3 Display configuration	6
6.4 Setting time/date	7
6.5 Setting the luminosity brightness	8
6.6 Display status	8
6.7 configuration of the display for data read-out from additional devices	8
7. INTERFACE	9
7.1 Registers: 4000...4031	9
7.2 Registers: 4300...4349	10
7.3 Registers: 7500...7653	14
8. TECHNICAL DATA	16
9. ORDER CODES	17
10. BEFORE A DAMAGE WILL BE DECLARED	18
11. MAINTENANCE AND SERVICE	19

January 2007

1. APPLICATION

Large-size digital displays of DL type are destined to display measured values or set values through the communication interface. Taking in consideration the application of 7-segment LED displays they are destined to be installed inside buildings.

The 100 mm digit height ensures a good readout from the distance of 40 m.

They find application in office accommodations, production workshops, in production management rooms as information about production parameters, state of machines or devices.

The displayed value is transmitted from external devices working in MODBUS standard. The display is working as the network „master“. The basic display version includes three digits and the unit, in two rows or three rows.

It is possible to make the display in the configuration required by the customer.

2. DISPLAY SET

The display set is composed of:

- DL11, DL12 or DL13 display 1 pc
- Suspension holder 2 pcs
- Diskette with software 1 pc
- User's manual 1 pc
- Guarantee card 1 pc

When unpacking the display, please check whether the type and execution code on the data plate correspond to the order.

3. BASIC REQUIREMENTS, OPERATIONAL SAFETY

Symbols located in this service manual mean:

WARNING!

Warning of potential, hazardous situations.

Especially important. One must acquaint with this before connecting the digital display.

The non-observance of notices marked by these symbols can occasion severe injuries of the personnel and the damage of the device.

CAUTION!

Designates a general useful note. If you observe it, handling of the device is made easier.

One must take note of this, when the device is working inconsistently to the expectations.

Possible consequences if disregarded!

In the security scope the digital display meets the requirements of the EEC

Low-Voltage Directive (EN 61010 -1 issued by CENELEC).

Remarks concerning the operator safety:

1. GENERAL

- The DL large displays are destined to be mounted in accordance with customer's requirements.
- Non-authorized removal of the required housing, inappropriate use, incorrect installation or operation creates the risk of injury to personnel or damage to equipment. For more detailed information please study the User's Manual.
- All operations concerning transport, installation, and commissioning as well as maintenance must be carried out by qualified, skilled personnel and national regulations for the prevention of accidents must be observed.
- According to this basic safety information, qualified, skilled personnel are persons who are familiar with the installation, assembly, commissioning, and operation of the product and who have qualifications necessary for their occupation.

2. TRANSPORT, STORAGE

- Please observe the notes on transport, storage and appropriate handling.
- Observe the climatic conditions given in Technical Data.

3. INSTALLATION

- The DL digital display must be installed according to the regulation and instructions given in this User's Manual.
- Ensure proper handling and avoid mechanical stress.
- Do not bend any components and do not change any insulation distances.
- Do not touch any electronic components and contacts.
- Devices may contain electrostatically sensitive components, which can easily be damaged by inappropriate handling.

Do not damage or destroy any electrical components since this might endanger your health!

4. ELECTRICAL CONNECTION

- Before switching the device on, one must check the correctness of connection to the network.
- In case of the protection terminal connection with a separate lead one must remember to connect it before the connection of the device to the mains.
- When working on live devices, the applicable national regulations for the prevention of accidents must be observed.
- The electrical installation must be carried out according to the appropriate regulations (cable cross-sections, fuses, PE connection). Additional information can be obtained from the user's guide.
- The documentation contains information about installation in compliance with EMC (shielding, grounding, filters and cables). These notes must be observed for all CE-marked products.
- The manufacturer of the digital display or installed devices is responsible for the compliance with the required limit values demanded by the EMC legislation.
- Do not connect the digital display to the mains through an autotransformer.
- The RS-485 socket serves only to connect devices working with the MODBUS protocol.

5. OPERATION

- Measuring systems including DL digital displays, must be equipped with protection devices according to the corresponding standard and regulations for prevention of accidents.
- After the display has been disconnected from the supply voltage, live components and power connections must not be touched immediately because capacitors can be charged.
- The housing must be closed during operation.
- The protection degree ensured by the housing is defined as IP40 and IP10 from the connection side.

6. MAINTENANCE AND SERVICING

- Please observe the manufacturer's documentation.
- Read all product-specific safety and application notes in this User's Manual.
- Before taking the device housing out, one must turn the supply off.
- The removal of the device housing during the guarantee contract period may cause its cancellation.

4. DESIGN DESCRIPTION AND INSTALLATION

The display housing is made of profiles and aluminium sheets, painted in black colour.

The frontal surface is made of polycarbonate as an anti-reflexive glass.

The protection degree ensured by the housing is defined as IP40.

The view and overall dimensions of DL11, DL12 and DL13 displays are presented on fig. 1, 2 and 3.

The design enables to fix the display on a wall.

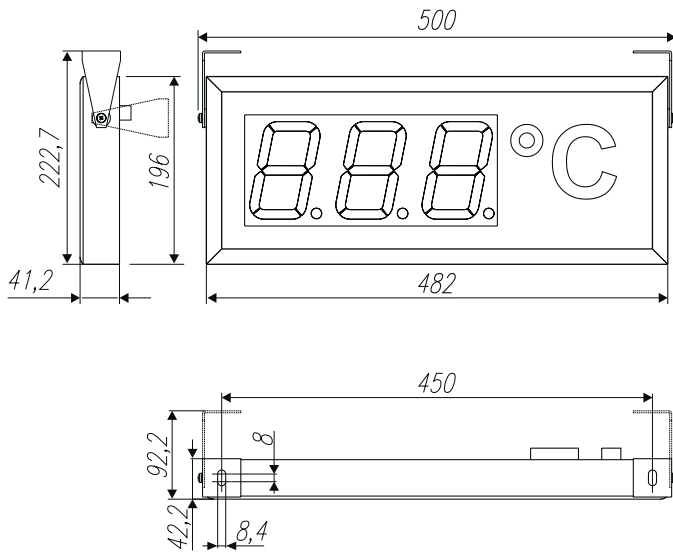

Fig.1 overall dimensions of the DL11 display.

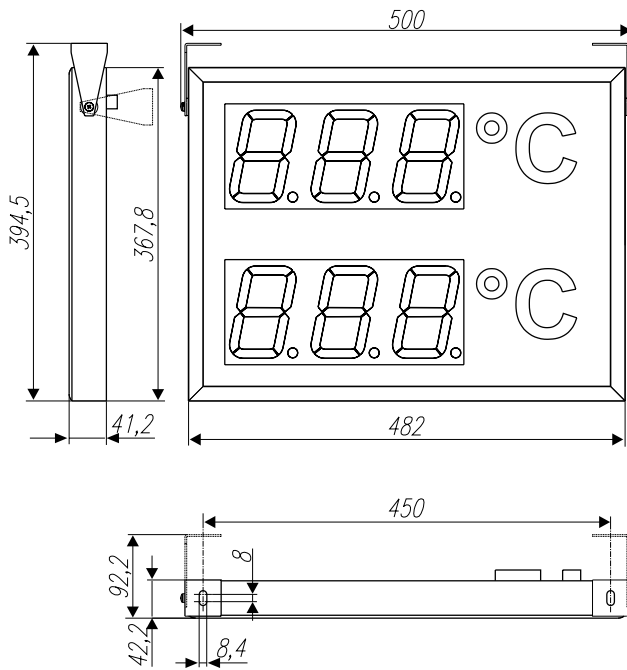

Fig.2 overall dimensions of the DL12 display.

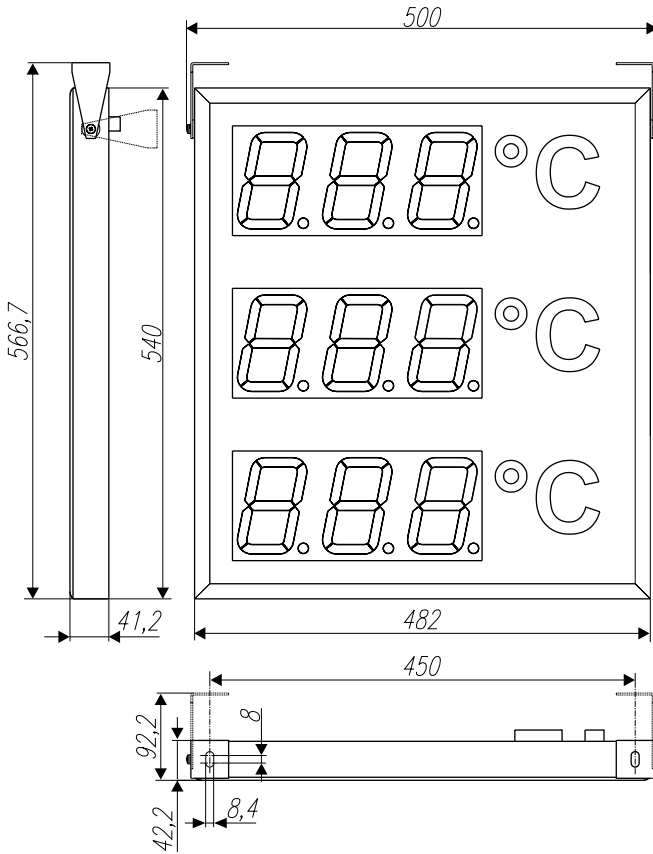

Fig.3 overall dimensions of the DL13 display

5. ELECTRICAL CONNECTIONS

Caution: the installation and display connections should be carried out by a qualified personnel.

The connection of supplying wires and interface should be carried out only in accordance with the user's manual. In case of inconsistent connections with the assigned connectors the display can be damaged. For the connection of control signals one must apply a wire coil in a shield.

In case of an environment with a low level of noise it is admissible to apply a wire coil non-shielded.

Caution: in case of a sudden change of the ambient temperature, dew may occur and it is forbidden to connect the display to the supply. It is recommended before mounting the display which changes suddenly its temperature, to wait at least 60 minutes before the first start.

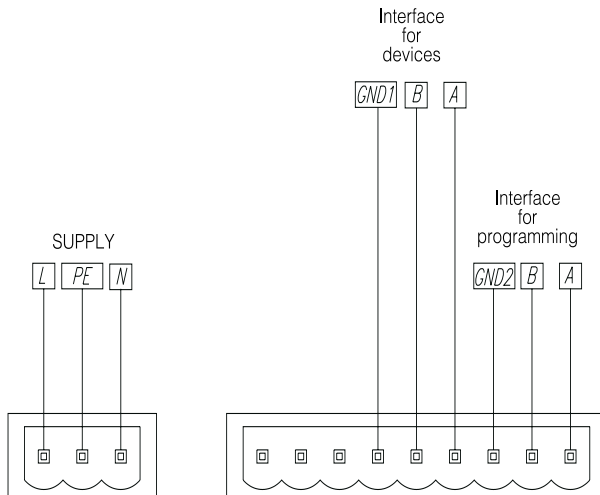
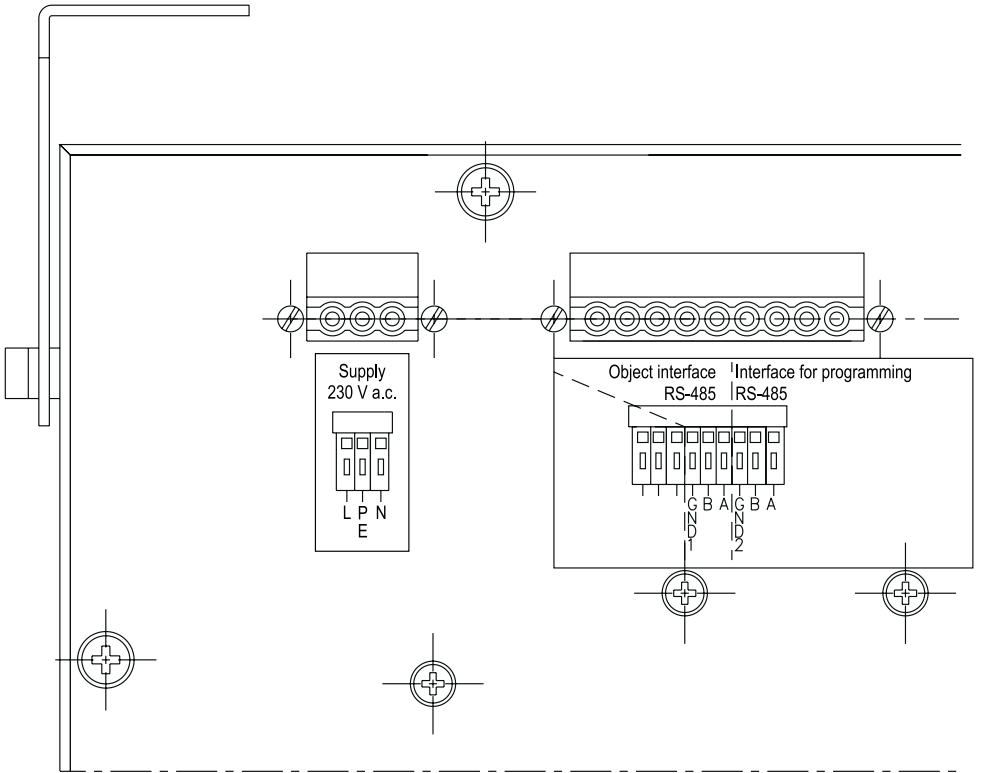

Fig.4. Markings of connectors for DL11, DL12, DL13:

6. CONFIGURATION OF THE DL DISPLAY

The DL11 display is default configured to the display of values being in the register 7500.

The change of display parameters is carried out through the suitable modification of values in configuring registers. To change parameters, one can use any program destined to read-out and write registers in MODBUS RTU networks.

Together with the display, a program for the display configuration is delivered, allowing the modification of all accessible parameters.



Before carrying out changes of the given parameter, it is recommended to carry out the read-out of the current configuration and modify the chosen parameter.

Transmission default parameters of the DL1 display:

- address in the network: 1
- transmission mode: RTU8n2
- baud rate: 9600 bit/sec.

Transmission parameters can be freely changed by the user. It is recommended to write new and previous transmission parameters.

The view of the main window of the DL1 program is presented on the window design.

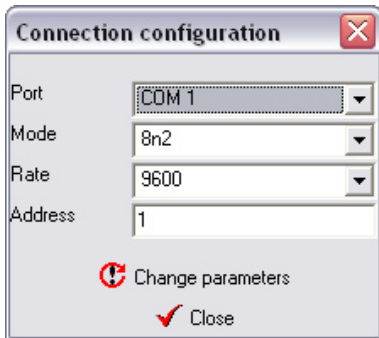

6.1. Connection configuration

In order to configure connections, one must choose the option „Connection configuration” from the main program window. Then, the dialog window presented on the design will start.

After choosing connection parameters, one can check the transmission correctness, choosing the option „Check” or close the window in order to a further work with the program.

Moreover, the user can also choose the option „Change parameters” serving to change parameters - see section 6.2. „Change of transmission parameters..”

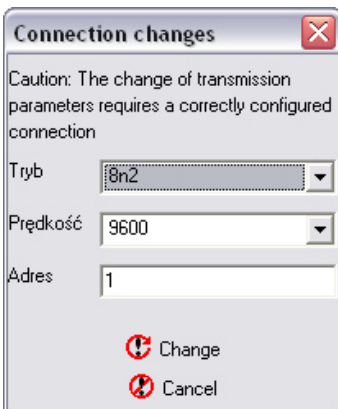

6.2. Changing transmission parameters”

In order to change connection parameters, one must choose „Connection configuration” and next, choose the option *Change Parameters* in the dialog window *Connection Configuration*.

Caution: The change of transmission parameters can be only made when the connection is correctly configured..

In the dialog window *Connection Change*, the user must give required connection parameters and choose *Change* in order to change connection parameters or *Cancel*, to resign of introducing changes.

6.3. Display configuration

The dialog window Display Configuration serves to the display configuration. The display field can be freely configured. It is admitted that one display row is destined to display one quantity. The DL1 program services displays composed maximally of four rows.

In order to change display configuration it is recommended to read out the current configuration, and next to modify it suitably.

The marking of fields in the dialog window is as follows:

- Number of digits - means the number of digits in the row. The zero value, means the lack of row. The first row must include one digit at least.
- Display format - the number of digits after the decimal point, defines the number of places after the decimal point that will be displayed.
- Displayed register - defines the register index, the value of which will be displayed on the display.
- Turn the alarm on - causes the flickering switching of the display after exceeding given values, signalling in this way the alarm state. Threshold values for the alarm are given in the textual fields situated under the switch *Turn the alarm on*.

After carrying out the modification, the configuration write is made by the push-button *Write the configuration*.

6.4. Setting time /date

The setting of the current time and date of the internal real time clock is carried out through the choice of the Time/Date option in the main program window.

The user can select two options of time setting:

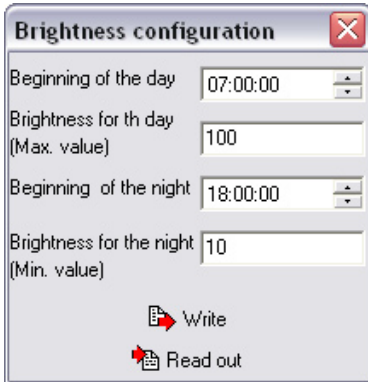
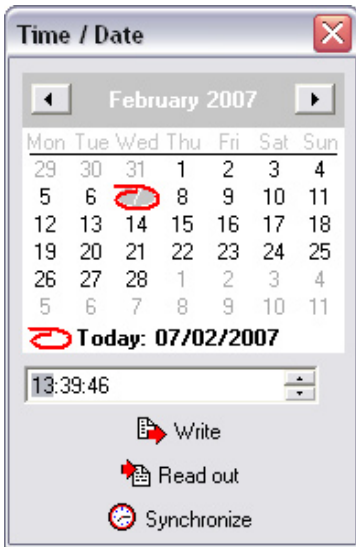

6.6. Display status

The selection of the option Show the Status in the main program window causes the readout of status registers from the DL display and the display of the window with informing flags. The set flags can be erased by the marking of the given flag.

The status informs the users about the state of the DL display controller and about the transmission state between the DL display and devices added to the display.

6.7. Display configuration for the data readout from added devices

One can configure the display for data readout from external devices working in the MODBUS RTU mode. All added devices must have identical transmission parameters and different addresses.

The register type, number of registers and register address from which begins the data readout, is freely configured by the user. The review period (frequency of data readout from the device) is programmed by the user. Taking in consideration the device response time, it may occur that the time between successive readouts will be longer than the programmed.

Data readout errors cause the setting of the check bit in the display status register. If errors occur in the communication with the device which the value is displayed, this will cause the display of an error

The write of time parameters and their write in the display or the selection of the *Synchronize* option, what will cause the time and date sampling from the computer and the write of these quantities to the display.

The selection of the *Synchronize* option performs the synchronization of the internal display clock with the computer clock with a one-second precision, however the time write, by giving the date and time value, is carried out with a one-minute precision (seconds introduced by the user are omitted).

6.5. Setting the luminosity brightness

DL displays have the possibility to program the luminosity brightness definition. The luminosity brightness can be defined in two time periods, named in the program as brightness for the day and brightness for the night. It is possible to set the brightness in such a way that the display will be switched on (increasing the brightness) in the defined hour and switched off automatically (decreasing the brightness) in the foreseen hour.

The brightness configuration consists of defining the starting hour for the day and for the night and defining the brightness for these periods.

transmission message  on the readout field.

The configuration of data readout parameters is carried out in the program after choosing the option Added Devices from the main program menu what will cause the display of the dialog window presented below.

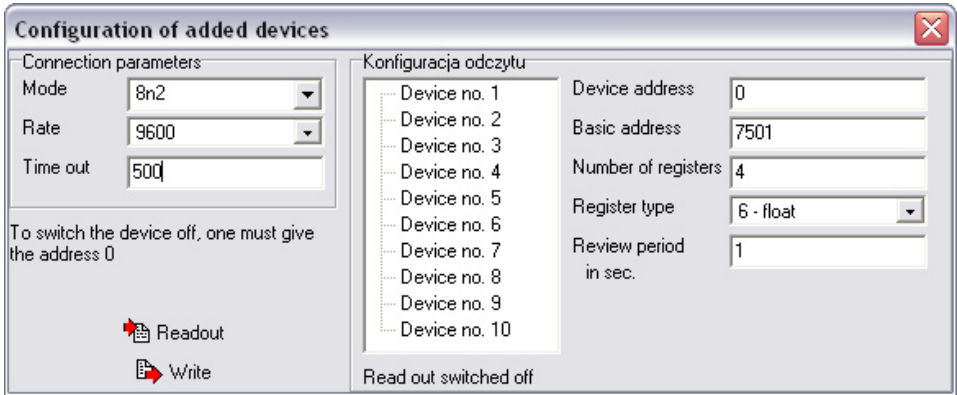

Connection parameters		Konfiguracja odczytu	
Mode	8n2	Device no. 1	Device address
Rate	9600	Device no. 2	Basic address
Time out	500	Device no. 3	Number of registers
		Device no. 4	Register type
		Device no. 5	Review period
		Device no. 6	in sec.
		Device no. 7	
		Device no. 8	
		Device no. 9	
		Device no. 10	

The user must define connection parameters, i.e. transmission mode, baud rate and the waiting time to the device response (time out) given in milliseconds. In order to configure the given device, one must choose the device to be configured from the list, and next give data readout parameters. To switch the device off, one must give the zero value as the address.

Before each configuration parameter change, it is recommended to carry out the configuration readout from the display, and after its modification, choose the option write in order to write changes into the display.

7. INTERFACE

DL11, DL12 and DL13 displays are equipped with two communication interfaces working in MODBUS RTU standard. The type of transmission frame and the baud rate are configured through the write of suitable values into the register.

The interface nr 1 is working all the time in the mode of the slave device (*slave*) and is destined to configure display parameters or the change of the displayed quantity.

The interface nr 2 is working in the master mode in the network and serves to the data readout from additional devices added to the display.

Displays possess the implemented MODBUS function:

- Function 3 - readout of n registers
- Function 16 - write of n registers
- Function 17 - identification of the device.

In order to data readout from external devices, the display unfairs advantage of the function nr 3.

Controller registers are divided into 3 groups:

- Registers 4000...4031 - hexadecimal bit registers destined for the configuration of connection parameters, display and systemic registers,
- Registers 4300...4349 - hexadecimal bit registers destined for the readout configuration from external devices working in MODBUS RTU standard,
- Register 7500...7653 - thirty-two bit registers of float type including data read out from external devices, measured values and registers of general assignments.

Caution: Values in general registers 7600...7609 have the 1E+20 value after switching the supply on,

and the value written in these registers is not stored after switching the supply off. The value introduced in general registers with addresses: 7614...7641, is written in the non-volatile controller memory.

The switching of the panel on does not cause the lost of values written in these registers.

If the register value to display is higher than $1E+20$, then it will be decreased to the $1E+20$ value.

If the register value to display is lower than $-1E+20$, then it will be increased to the $-1E+20$ value.

The data readout from external devices is carried out with a ca 200 ms interval between successive queries and can be subject to extension in case when the added devices have a long response time to the query. In case of switching all devices on, or questioning devices with long response time, it can happen that the time between successive data readouts from the given device will be longer than the programmed in the panel, what has a relation with response times of devices added to the display and the number of these devices.

If the added device to the display does not respond or the response is erroneous, then registers with readout values will be filled with $1E+20$ values.

7.1. Registers 4000... 4031

Register address	Operations	Range	Description
4000	RW	1...247	Address of interface nr 1 - user's interface
4001	RW	0...3	Working mode of interface nr 1: 0: RTU 8N1 1: RTU 8N2 2: RTU 8E1 3: RTU 8O1
4002	RW	0...9	Baud rate of interface nr1 [b/s]: 0 – 2400; 1 – 4800; 2 – 9600; 3 – 14400; 4 – 19200; 5 – 28800; 6 – 38400; 7 – 57600; 8 – 76800; 9 – 115200
4003	RW	1...50	Waiting time to the response of slave device for the port 2 expressed as the multiple of 100 ms
4004	RW	0...3	Working mode of interface nr 2 0: RTU 8N1 1: RTU 8N2 2: RTU 8E1 3: RTU 8O1
4005	RW	0...9	Baud rate of interface nr2 [b/s]: 0 – 2400; 1 – 4800; 2 – 9600; 3 – 14400; 4 – 19200; 5 – 28800; 6 – 38400; 7 – 57600; 8 – 76800; 9 – 115200
Konfiguracja of display rows			
Row number 1			
4006	RW	1...20	Number of digits in the first row
4007	RW	0...3	Display format - number of places after the decimal point
4008	RW	0...149	Number of the register to display, as the shift in respect to the address 7500

4009	RW	0,1	Switch the alarm on
Row number II			
4010	RW	0...20	Number of digits in the second row
4011	RW	0...3	Display format - number of places after the decimal point
4012	RW	0...149	Number of the register to display, as the shift in respect to the address 7500
4013	RW	0,1	Switch the alarm on
Row number III			
4014	RW	0...20	Number of digits in the third row
4015	RW	0...3	Display format - number of places after the decimal point
4016	RW	0...149	Number of the register to display, as the shift in respect to the address 7500
4017	RW	0,1	Switch the alarm on
Row number IV			
4018	RW	0...20	Number of digits in the fourth row
4019		0...3	Display format - number of places after the decimal point
4020	RW	0...149	Number of the register to display, as the shift in respect to the address 7500
4021	RW	0,1	Switch the alarm on
Time and date			
4022	RW	2001...2100	Current year in the YYYY format
4023	RW	101...1231	Current date in the MMDD format
4024	RW	0000...2359	Current time in the GGMM FORMAT
Luminosity brightness			
4025	RW	1...100	Brightness for the day
4026	RW	1...100	Brightness for the night
4027	RW	0000...2359	Beginning of the day
4028	RW	0000...2359	Beginning of the night
Systemic registers			
4029	RW	No concerns	Status – Successive bits represent flags informing about events: Bit 15 – work in service mode - requires service authorization; Bit 14 – Error of EEPROM memory - manufacturer settings are restored; Bit 13 – Error of the RTC clock settings or uncertain settings; Bit 12 – the summer/winter time was changed or inversely; Bit 11 – Error of the external lighting sensor (only for options made with a sensor); Bit 10 – Break in the supply; Bit 09 – Measurement error in the line 2 - value beyond the range; Bit 08 – Measurement error in the line 1 - value beyond the range; Bits 07...00 – no used - always value 0.

4030	RW	No concerns	Status of devices added to the display. Successive bits inform about the transmission state with slave devices: Bit 15 – There were transmission errors; Bit 09 – error of the device number 10; Bit 08 – error of the device number 9; Bit 07 – error of the device number 8; Bit 06 – error of the device number 7; Bit 05 – error of the device number 6; Bit 04 – error of the device number 5; Bit 03 – error of the device number 4; Bit 02 – error of the device number 3; Bit 01 – error of the device number 2; Bit 00 – error of the device number 1;
4031	RW	No concerns	Access code to the calibration data and some configuration settings. In order to change calibration coefficients, one must introduce the correct password.

7.2. Registers 4300... 4349

Register address	Operations	Range	Description
Device number 1			
4300	RW	0,1...247	Slave device address. 0 - switches the device off
4301	RW	0...65535	Basic address
4302	RW	1...10	Number of read out registers
4303	RW	0...6	Register type: 0 - variable of char type 1 - variable of unsigned char type 2 - variable of integer type 3 - variable of unsigned integer type 4 - variable of long type 5 - variable of unsigned long type 6 - variable of float type
4304	RW	1...60	Review period in seconds. Defines the asking frequency of the slave device.
Device number 2			
4305	RW	0,1...247	Slave device address. 0 - switches the device off
4306	RW	0...65535	Basic address
4307	RW	1...10	Number of read out registers
4308	RW	0...6	Register type: 0 - variable of char type 1 - variable of unsigned char type 2 - variable of integer type 3 - variable of unsigned integer type 4 - variable of long type 5 - variable of unsigned long type 6 - variable of float type
4309	RW	1...60	Review period in seconds. Defines the asking frequency of the slave device.

Device number 3			
4310	RW	0,1...247	Slave device address. 0 - switches the device off
4311	RW	0...65535	Basic address
4312	RW	1...10	Number of read out registers
4313	RW	0...6	Register type: 0 - variable of char type 1 - variable of unsigned char type 2 - variable of integer type 3 - variable of unsigned integer type 4 - variable of long type 5 - variable of unsigned long type 6 - variable of float type
4314	RW	1...60	Review period in seconds. Defines the asking frequency of the slave device.
Device number 4			
4315	RW	0,1...247	Slave device address. 0 - switches the device off
4316	RW	0...65535	Basic address
4317	RW	1...10	Number of read out registers
4318	RW	0...6	Register type: 0 - variable of char type 1 - variable of unsigned char type 2 - variable of integer type 3 - variable of unsigned integer type 4 - variable of long type 5 - variable of unsigned long type 6 - variable of float type
4319	RW	1...60	Review period in seconds. Defines the asking frequency of the slave device.
Device number 5			
4320	RW	0,1...247	Slave device address. 0 - switches the device off
4321	RW	0...65535	Basic address
4322	RW	1...10	Number of read out registers
4323	RW	0...6	Register type: 0 - variable of char type 1 - variable of unsigned char type 2 - variable of integer type 3 - variable of unsigned integer type 4 - variable of long type 5 - variable of unsigned long type 6 - variable of float type
4324	RW	1...60	Review period in seconds. Defines the asking frequency of the slave device.
Device number 6			
4325	RW	0,1...247	Slave device address. 0 - switches the device off
4326	RW	0...65535	Basic address
4327	RW	1...10	Number of read out registers

4328	RW	0...6	Register type: 0 - variable of char type 1 - variable of unsigned char type 2 - variable of integer type 3 - variable of unsigned integer type 4 - variable of long type 5 - variable of unsigned long type 6 - variable of float type
4329	RW	1...60	Review period in seconds. Defines the asking frequency of the slave device.
Device number 7			
4330	RW	0,1...247	Slave device address. 0 - switches the device off
4331	RW	0...65535	Basic address
4332	RW	1...10	Number of read out registers
4333	RW	0...6	Register type: 0 - variable of char type 1 - variable of unsigned char type 2 - variable of integer type 3 - variable of unsigned integer type 4 - variable of long type 5 - variable of unsigned long type 6 - variable of float type
4334	RW	1...60	Review period in seconds. Defines the asking frequency of the slave device.
Device number 8			
4335	RW	0,1...247	Slave device address. 0 - switches the device off
4336	RW	0...65535	Basic address
4337	RW	1...10	Number of read out registers
4338	RW	0...6	Register type: 0 - variable of char type 1 - variable of unsigned char type 2 - variable of integer type 3 - variable of unsigned integer type 4 - variable of long type 5 - variable of unsigned long type 6 - variable of float type
4339	RW	1...60	Review period in seconds. Defines the asking frequency of the slave device.
Device number 9			
4340	RW	0,1...247	Slave device address. 0 - switches the device off
4341	RW	0...65535	Basic address
4342	RW	1...10	Number of read out registers
4343	RW	0...6	Register type: 0 - variable of char type 1 - variable of unsigned char type 2 - variable of integer type 3 - variable of unsigned integer type 4 - variable of long type 5 - variable of unsigned long type 6 - variable of float type

4344	RW	1...60	Review period in seconds. Defines the asking frequency of the slave device.
Device number 10			
4345	RW	0,1...247	Slave device address. 0 - switches the device off
4346	RW	0...65535	Basic address
4347	RW	1...10	Number of read out registers
4348	RW	0...6	Register type: 0 - variable of char type 1 - variable of unsigned char type 2 - variable of integer type 3 - variable of unsigned integer type 4 - variable of long type 5 - variable of unsigned long type 6 - variable of float type
4349	RW	1...60	Review period in seconds. Defines the asking frequency of the slave device.

7.3. Registers 7500... 7653

Adres rejestru	Operacije	Zakres	Opis
7500	R	n.d.	Device 1 – First register read out
7501	R	n.d.	Device 1 – Second register read out.
7502	R	n.d.	Device 1 – Third register read out
7503	R	n.d.	Device 1 – fourth register read out
7504	R	n.d.	Device 1 – Fifth register read out
7505	R	n.d.	Device 1 – Sixth register read out
7506	R	n.d.	Device 1 – Seventh register read out
7507	R	n.d.	Device 1 – Eighth register read out
7508	R	n.d.	Device 1 – Ninth register read out
7509	R	n.d.	Device 1 – Tenth register read out
7510	R	n.d.	Device 2 – First register read out
7511	R	n.d.	Device 2 – Second register read out.
7512	R	n.d.	Device 2 – Third register read out
7513	R	n.d.	Device 2 – fourth register read out
7514	R	n.d.	Device 2 – Fifth register read out
7515	R	n.d.	Device 2 – Sixth register read out
7516	R	n.d.	Device 2 – Seventh register read out
7517	R	n.d.	Device 2 – Eighth register read out
7518	R	n.d.	Device 2 – Ninth register read out
7519	R	n.d.	Device 2 – Tenth register read out
7520	R	n.d.	Device 3 – First register read out
7521	R	n.d.	Device 3 – Second register read out.
7522	R	n.d.	Device 3 – Third register read out

7523	R	n.d.	Device 3 – fourth register read out
7524	R	n.d.	Device 3 – Fifth register read out
7525	R	n.d.	Device 3 – Sixth register read out
7526	R	n.d.	Device 3 – Seventh register read out
7527	R	n.d.	Device 3 – Eighth register read out
7528	R	n.d.	Device 3 – Ninth register read out
7529	R	n.d.	Device 3 – Tenth register read out
7530	R	n.d.	Device 4 – First register read out
7531	R	n.d.	Device 4 – Second register read out.
7532	R	n.d.	Device 4 – Third register read out
7533	R	n.d.	Device 4 – fourth register read out
7534	R	n.d.	Device 4 – Fifth register read out
7535	R	n.d.	Device 4 – Sixth register read out
7536	R	n.d.	Device 4 – Seventh register read out
7537	R	n.d.	Device 4 – Eighth register read out
7538	R	n.d.	Device 4 – Ninth register read out
7539	R	n.d.	Device 4 – Tenth register read out
7540	R	n.d.	Device 5 – First register read out
7541	R	n.d.	Device 5 – Second register read out.
7542	R	n.d.	Device 5 – Third register read out
7543	R	n.d.	Device 5 – fourth register read out
7544	R	n.d.	Device 5 – Fifth register read out
7545	R	n.d.	Device 5 – Sixth register read out
7546	R	n.d.	Device 5 – Seventh register read out
7547	R	n.d.	Device 5 – Eighth register read out
7548	R	n.d.	Device 5 – Ninth register read out
7549	R	n.d.	Device 5 – Tenth register read out
7550	R	n.d.	Device 6 – First register read out
7551	R	n.d.	Device 6 – Second register read out.
7552	R	n.d.	Device 6 – Third register read out
7553	R	n.d.	Device 6 – fourth register read out
7554	R	n.d.	Device 6 – Fifth register read out
7555	R	n.d.	Device 6 – Sixth register read out
7556	R	n.d.	Device 6 – Seventh register read out
7557	R	n.d.	Device 6 – Eighth register read out
7558	R	n.d.	Device 6 – Ninth register read out
7559	R	n.d.	Device 6 – Tenth register read out
7560	R	n.d.	Device 7 – First register read out
7561	R	n.d.	Device 7 – Second register read out.

7562	R	n.d.	Device 7 – Third register read out
7563	R	n.d.	Device 7 – fourth register read out
7564	R	n.d.	Device 7 – Fifth register read out
7565	R	n.d.	Device 7 – Sixth register read out
7566	R	n.d.	Device 7 – Seventh register read out
7567	R	n.d.	Device 7 – Eighth register read out
7568	R	n.d.	Device 7 – Ninth register read out
7569	R	n.d.	Device 7 – Tenth register read out
7570	R	n.d.	Device 8 – First register read out
7571	R	n.d.	Device 8 – Second register read out.
7572	R	n.d.	Device 8 – Third register read out
7573	R	n.d.	Device 8 – fourth register read out
7574	R	n.d.	Device 8 – Fifth register read out
7575	R	n.d.	Device 8 – Sixth register read out
7576	R	n.d.	Device 8 – Seventh register read out
7577	R	n.d.	Device 8 – Eighth register read out
7578	R	n.d.	Device 8 – Ninth register read out
7579	R	n.d.	Device 8 – Tenth register read out
7580	R	n.d.	Device 9 – First register read out
7581	R	n.d.	Device 9 – Second register read out.
7582	R	n.d.	Device 9 – Third register read out
7583	R	n.d.	Device 9 – fourth register read out
7584	R	n.d.	Device 9 – Fifth register read out
7585	R	n.d.	Device 9 – Sixth register read out
7586	R	n.d.	Device 9 – Seventh register read out
7587	R	n.d.	Device 9 – Eighth register read out
7588	R	n.d.	Device 9 – Ninth register read out
7589	R	n.d.	Device 9 – Tenth register read out
7590	R	n.d.	Device 10 – First register read out
7591	R	n.d.	Device 10 – Second register read out.
7592	R	n.d.	Device 10 – Third register read out
7593	R	n.d.	Device 10 – fourth register read out
7594	R	n.d.	Device 10 – Fifth register read out
7595	R	n.d.	Device 10 – Sixth register read out
7596	R	n.d.	Device 10 – Seventh register read out
7597	R	n.d.	Device 10 – Eighth register read out
7598	R	n.d.	Device 10 – Ninth register read out
7599	R	n.d.	Device 10 – Tenth register read out
7600	RW	n.d.	General register nr 1

7601	RW	n.d.	General register nr 2
7602	RW	n.d.	General register nr 3
7603	RW	n.d.	General register nr 4
7604	RW	n.d.	General register nr 5
7605	RW	n.d.	General register nr 6
7606	RW	n.d.	General register nr 7
7607	RW	n.d.	General register nr 8
7608	RW	n.d.	General register nr 9
7609	RW	n.d.	General register nr 10
7610	RW	n.d.	Alarm 1 – down limitation
7611	RW	n.d.	Alarm 1 – up limitation
7612	RW	n.d.	Alarm 2 – down limitation
7613	RW	n.d.	Alarm 2 – up limitation
7614	RW	n.d.	Alarm 3 – down limitation
7615	RW	n.d.	Alarm 3 – up limitation
7616	RW	n.d.	Alarm 4 – down limitation
7617	RW	n.d.	Alarm 4 – up limitation
7618	RW	n.d.	General register
7619	RW	n.d.	General register
7620	RW	n.d.	General register
7621	RW	n.d.	General register
7622	RW	n.d.	General register
7623	RW	n.d.	General register
7624	RW	n.d.	General register
7625	RW	n.d.	General register
7626	RW	n.d.	General register
7627	RW	n.d.	General register
7628	RW	n.d.	General register
7629	RW	n.d.	General register
7630	RW	n.d.	General register
7631	RW	n.d.	General register
7632	RW	n.d.	General register
7633	RW	n.d.	General register
7634	RW	n.d.	General register
7635	RW	n.d.	General register
7636	RW	n.d.	General register
7637	RW	n.d.	General register
7638	RW	n.d.	General register
7639	RW	n.d.	General register

7640	RW	n.d.	General register
7641	RW	n.d.	General register

8. TECHNICAL DATA

Readout field:

Digit height: 100 mm

DL11 one row of 3 digits + unit field

DL12 two rows of 3 digits + unit field

DL13 three rows of 3 digits + unit field

Colour of the readout field:

Red, green and yellow - possibility of colour combination for DL12 and DL13

Power consumption:

DL11 < 12VA

DL12 < 24VA

DL13 < 36VA

Communication:

Interface RS-485

Transmission protocol: MODBUS

Reaction against decay and supply recovery:

Preservation of configuration data in the display.

Dimensions:

DL11 482 x 196 x 41 mm

DL12 482 x 368 x 41 mm

DL13 482 x 540 x 41 mm

Reference conditions and rated operational conditions:

- working temperature 0...**23**...50°C
- storage temperature -20... 75°C
- humidity 25... 95%
- supply 85...**230**...253 V a.c.
- frequency 45...**50**...60 Hz
- external magnetic field 0...**40**...400 A/m
- working position any

Standards fulfilled by panels:

Electromagnetic compatibility:

- noise emissions acc. to EN 61000-6-4
- noise immunity acc. to EN 61000-6-2
- resistance to supply decay acc. to EN 61000-6-2

Safety requirements:

acc. to EN 61010-1

- isolation ensured by the housing: basic
- isolation between circuits: basic
- installation category: III
- pollution degree: 2
- maximal working voltage in relation to earth for supply circuits: 300 V, and 50 V for others.

9. ORDER CODES

Table 1

DIGITAL DISPLAY	DL11 -	X	XX
Colour of display field:			
Red		R	
Yellow		Y	
Green.....		G	
Kind of versions:			
Standard			00
custom-made*			XX

Table 2

DIGITAL DISPLAY	DL12 -	X	X	XX
Colour of the I display field:				
Red		R		
Yellow		Y		
Green.....		G		
Colour of the II display field:				
Red			R	
Yellow			Y	
Green.....			G	
Kind of versions:				
Standard				00
custom-made*				XX

Table 3

DIGITAL DISPLAY	DL13 -	X	X	X	XX
Colour of the I display field:					
Red		R			
Yellow		Y			
Green.....		G			
Colour of the II display field:					
Red				R	
Yellow				Y	
Green.....				G	
Colour of the III display field:					
Red					R
Yellow					Y
Green.....					G
Kind of versions:					
Standard					00
custom-made*					XX

Caution: when ordering, one must give communication parameters of the measuring devices

Coding Example

The Code: **DL13 - R Y G 00** means:

DL13 - Digital display consisting of 3 rows

R - digits in the upper row are red

Y - digits in the middle row are yellow

G - digits in the lower row are green

00 - in standard version

Other versions of displays are possible acc. customer's needs after agreeing with the manufacturer.

10. BEFORE A DAMAGE WILL BE DECLARED

If the display remains inconsistently with the customer expectations, one must firstly check the display configuration.

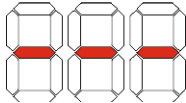
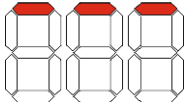
Problem	Solution
Lack of display	One must check the connection correctness
Displayed symbol 	The displayed symbol signals a lack of transmission with the device which the value has to be displayed from. One must check the correctness of the interface connection and the configuration of additional devices.
Displayed symbol 	The value to display cannot be situated in the display field. The value is too high to be displayed.
Lack of communication with the display	Check the correctness of connections and check the correctness of transmission parameter settings. In case when settings are unknown, one must contact the manufacturer or try lately used settings
The displayed result is incomplete. Lack of the most significant digits	One must check, if the introduced number of digits for the given row is not higher than the physical number of display digits (for the given row).

11. MAINTENANCE AND SERVICE

Displays of DL type do not require a periodical maintenance. One cannot use solvents, petrols, corrosive means, which can damage painted surfaces of the display or the frontal glass. Antielectrostatic cleaning foams are the most suitable to clean the display.

When washing the display, one must take care that moisture does not penetrate inside the display.

In case of some incorrect operations:

1. After the dispatch date and within the period stated in the guarantee card

One should return the device to the LUMEL's Quality Inspection Dept.

If the device has been used in compliance with the instructions, LUMEL S.A. guarantees to repair it free of charge.

The disassembling of the housing causes the cancellation of the granted guarantee.

2. After the guarantee period:

One should send the device to repair it in an authorized service workshop. Spare parts are available for the period of five years from the date of purchase.

LUMEL S.A. policy is one of continuous improvement and we reserve the right to make changes in design and specifications of any products as engineering advances or necessity requires and revise the above specifications without notice.

SALES PROGRAM

- DIGITAL and BARGRAPH PANEL METERS
- MEASURING TRANSDUCERS
- ANALOG PANEL METERS (DIN INSTRUMENTS)
- ANALOG and DIGITAL CLAMP-ON METERS
- INDUSTRIAL and HOUSEHOLD CONTROLLERS
- CHART AND PAPERLESS RECORDERS
- POWER CONTROL UNITS and RELAYS
- AUTOMOTIVE DASHBOARD INDICATORS
- ELECTRONIC WATT-HOUR-METERS
- ACCESSORIES FOR MEASURING INSTRUMENTS
- MEASURING SYSTEMS (ENERGY, HEAT, CONTROL)
- CUSTOM-MADE PRODUCTS

WE ALSO OFFER OUR SERVICES IN THE PRODUCTION OF:

- ALUMINIUM ALLOY PRESSURE CASTINGS
- PRECISION ENGINEERING AND THERMOPLASTICS PARTS
- ASSEMBLY OF PC BOARDS and ELECTRONIC DEVICES

QUALITY PROCEDURES

According to ISO 9001 and ISO 14001 international requirements.

All our instruments have CE mark .

For more information, please write to or phone our Export Department

**MEASUREMENT
CONTROL
RECORDING**



Lubuskie Zakłady Aparatów Elektrycznych LUMEL S.A.

ul. Sulechowska 1, 65-022 Zielona Góra, Poland

Tel.: (48-68) 329 51 00 (exchange)

Fax: (48-68) 329 51 01

e-mail: lumel@lumel.com.pl

<http://www.lumel.com.pl>

Export Department:

Tel.: (48-68) 329 53 02 or 53 04

Fax: (48-68) 325 40 91

e-mail: export@lumel.com.pl