

# TEMPERATURE CONTROLLER

## RE55 type



### APPLICATION

The R55 controller is a microprocessor controller with an analog setting and digital measurement of the measured value. The controller controls the temperature in objects through switching on and off the electrical control device, in accordance with the definite set point by the controller.

The controller co-operates directly with RTD and TC temperature sensors.

The controller is destined to control temperature in plastics industry, food and dehydration industries, and everywhere when it is necessary to stabilize temperature changes.

### TECHNICAL DATA

#### Potentiometric setting of the set point:

- resolution of the set point setting 0.1% of the controller range
- difference between the set point and the value set on the graduation < 2% of the controller range

**Measurement time** 0.5 s

#### Error detection in the measurement circuit:

- thermocouple, Pt100 measuring range exceeding

#### Control algorithm

P, PD, PI, PID, ON-OFF with hysteresis - PID controller

#### Setting range of controller parameters

see table 1

#### Kinds of outputs:

for control output:

- relay without voltage change-over contact load 2 A/230 V
- logic voltage 5 V voltage, 10 Ω resistance limiting the current (without isolation from the sensor side)

for alarm output:

- relay without voltage normally open contact (NOC) load capacity 1A/230

#### Output operation:

- reverse for heating
- direct for cooling

#### Signalling:

- switching the main output on
- switching the main output off

#### Rated operating conditions:

- supply voltage 85...253 V a.c./d.c.
- supply voltage frequency 40...440 Hz
- ambient temperature 0...23...50°C
- storage temperature -20...+70°C
- relative air humidity < 85% (without condensation)
- preliminary warm-up time 30 min.
- external magnetic field < 400 A/m
- operating position any
- resistance of wires connecting the resistance thermometer with the controller < 10 Ω/wire

**Consumption** < 4 VA

**Weight** < 0.3 kg

**Overall dimensions** 96 × 96 × 65 mm

**Panel cut-out** 91<sup>+0.6</sup> × 91<sup>+0.6</sup> mm

#### Protection degree ensured by the housing: acc. to EN 60529

- from the frontal plate side IP 40
- from terminal side IP 20

#### Additional errors in rated operating conditions caused by:

- compensation of the thermocouple reference junction temperature change ≤ 2°C
- changes of the RTD line resistance ≤ 50% of the intrinsic error
- change of ambient temperature ≤ 100% of the intrinsic error/10 K

Range, resolution and based intrinsic error for different executions

Table 1

| Sensor type   | Range °C  | Resolution °C | Intrinsic error °C |
|---|-----------|---------------|--------------------|
| Resistance thermometer (acc. EN 60751+A2), measuring current 0,25mA |           |               |                    |
| Pt100*  | -50...100 | 0.1           | ± 0.8              |
|   | 0...100   | 0.1           | ± 0.5              |
|   | 0...150   | 0.1           | ± 0.8              |
|   | 0...250   | 0.1           | ± 1.3              |
|   | 0...400   | 0.1           | ± 2.0              |
| 0...600   | 0.1       | ± 3.0         |                    |
| Thermocouple of J type (acc. EN 60584-1)                            |           |               |                    |
| Fe-CuNi   | 0...250   | 0.1           | ± 2.0              |
|   | 0...400   | 0.1           | ± 2.0              |
|   | 0...600   | 0.1           | ± 3.0              |
|   | 0...900   | 0.1           | ± 4.0              |
| Thermocouple of K type (acc. EN 60584-1)                            |           |               |                    |
| NiCr-NiAl   | 0...600   | 0.1           | ± 3.0              |
|   | 0...900   | 0.1           | ± 4.0              |
|   | 0...1300  | 1             | ± 6.0              |
| Thermocouple of S type (acc. EN 60584-1)                            |           |               |                    |
| PtRh10-Pt   | 0...1600  | 1             | ± 8.0              |

\*) Sensor line resistance < 100 Ω/wire, one must make the connection with wires of identical cross-section and length

**Safety requirements acc. to EN 61010-1:**

- isolation between circuit      basic
- installation category            III
- pollution degree                2
- maximal working voltage in relation to earth:
  - for the supply circuit        300 V
  - for input circuits            50 V
- altitude above sea level        under 2000 m

**Electromagnetic compatibility:**

- immunity                        acc. to EN 61000-6-2
- emission                        acc. to EN 61000-6-4

**Overall and mounting dimensions**

Cut-out dimensions: 91<sup>+0,6</sup> x 91<sup>+0,6</sup>

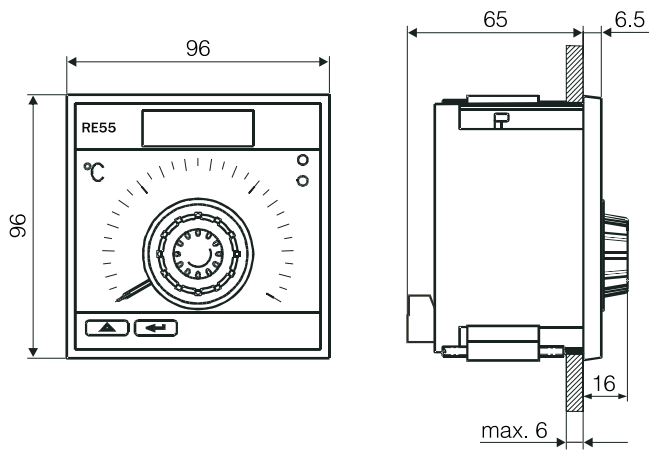

**Electrical connections of external circuits**

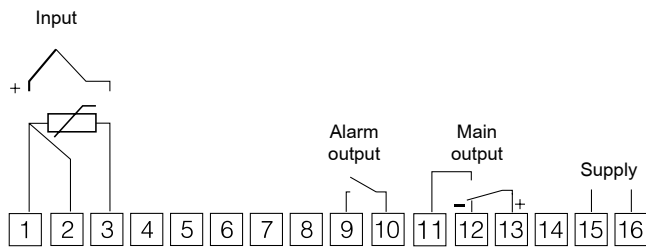

**ORDERING CODES**

| Temperatura controller                                    | RE55 -             | X  | X | X | X | X |
|---|--------------------|----|---|---|---|---|
| <b>Input:</b>   |                    |    |   |   |   |   |
| Pt100/1.3850  | - 50... 100°C..... | 01 |   |   |   |   |
|   | 0... 100°C.....    | 02 |   |   |   |   |
|   | 0... 150°C.....    | 03 |   |   |   |   |
|   | 0... 250°C.....    | 04 |   |   |   |   |
|   | 0... 400°C.....    | 05 |   |   |   |   |
|   | 0... 600°C.....    | 06 |   |   |   |   |
| Fe-CuNi (J)   | 0... 250°C.....    | 07 |   |   |   |   |
|   | 0... 400°C.....    | 08 |   |   |   |   |
|   | 0... 600°C.....    | 09 |   |   |   |   |
|   | 0... 900°C.....    | 10 |   |   |   |   |
| NiCr-NiAl (K)   | 0... 600°C.....    | 11 |   |   |   |   |
|   | 0... 900°C.....    | 12 |   |   |   |   |
|   | 0... 1300°C.....   | 13 |   |   |   |   |
| PtRh10-Pr (S)   | 0... 1600°C.....   | 14 |   |   |   |   |
| On order*   | .....              | 99 |   |   |   |   |
| <b>Kind of execution:</b>                                 |                    |    |   |   |   |   |
| on-off controller   | .....              | 1  |   |   |   |   |
| PID controller  | .....              | 2  |   |   |   |   |
| controller configurable by push-buttons and with an alarm | ....               | 3  |   |   |   |   |
| <b>Control output:</b>                                    |                    |    |   |   |   |   |
| relay   | .....              | 1  |   |   |   |   |
| voltage 0/5 V   | .....              | 2  |   |   |   |   |
| <b>Version:</b>   |                    |    |   |   |   |   |
| standard  | .....              | 0  |   |   |   |   |
| Custom-made   | .....              | 5  |   |   |   |   |
| <b>Acceptance tests:</b>                                  |                    |    |   |   |   |   |
| without a legalisation certificate                        | .....              | 8  |   |   |   |   |
| with a legalisation certificate                           | .....              | 7  |   |   |   |   |
| acc. customer's agreement**                               | .....              | X  |   |   |   |   |

\*) – After agreement with the manufacturer  
 \*\*) – The code will be established by the manufacturer

**EXAMPLE OF ORDER**

The code: **RE55 02 3 1 0 0** means:  
**RE55** - temperature controller of RE55 type  
**02** - input Pt100, range: 0...100°C  
**3** - execution: controller configurable by push-buttons and with an alarm  
**1** - control output: relay  
**0** - standard version  
**0** - without an additional quality certificate.