

Energom-P-2A

DC Insulation Monitoring Relay

User Manual



Version:1.0

Revision 2023.04

Read me

When you use EnergoM-P-2A DC insulation monitoring relay, be sure to read this user manual carefully, and be able to fully understand the implications, the correct guidance of operations in accordance with user manual, which will help you make better use of EnergoM-P-2A DC insulation monitoring relay, and help to solve the various problems at the scene.

1. Always keep safe distance between the instrument and operator.
2. Measurements must not be taken when thunderstorms are nearby.
3. Do not operate the instrument or accessories in explosive atmospheres.
4. Do not open the instrument without permission, this will affect the warranty of the product. The factory is not responsible for self-disassembly.
5. When the instrument is transported, it should avoid rain erosion and prevent collision and falling.
6. When storing and keeping the instrument, attention should be paid to the ambient temperature and humidity, and it should be protected from dust, moisture, shock, acid, alkali and corrosive gas.



- **Please read this user manual carefully**
- **Please save this document**

Directory

- 1.- SUMMARIZE - 3 -
- 2.- TECHNICAL PARAMETERS - 5 -
- 3.- INSTALLATION AND TERMINAL DEFINITION..... - 6 -
- 4.- OPERATING INSTRUCTIONS - 8 -
- 5.- SAFETY CONSIDERATIONS - 9 -
- 6.- TECHNICAL SERVICE..... - 9 -

1.- SUMMARIZE

The ZJJ - 4SA DC insulation relay adopts a fully static circuit, and has a highly sensitive grounding resistance monitoring and display circuit, which helps users make a quantitative assessment of the reduction of the insulation degree of the DC busbar, and monitors the grounding resistance of the positive and negative busbars online in real time. When the insulation drops below the set value, the relay sends out a warning signal.

Due to the use of a full-hardware divider calculation circuit, it can directly display the grounding resistance value, which solves the confusion caused by the old relays that have no display or can only display the grounding current, and must manually check the table; the alarm threshold also uses the resistance value. directly displayed. ZJJ-4SA adopts instrument structure with panel, are widely used in DC speed regulating motors, solar power generation and other fields.

WORKING PRINCIPLE

The relay uses the bridge balance method to measure the ground resistance on one side, as shown in the figure below. R1 and R2 are balanced resistors to realize balanced voltage division at point A. RL is the current measurement sampling resistance.

When a unilateral insulation voltage drop occurs, that is, when there is RX or RY, the grounding current produces a positive or negative voltage drop Vo on RL. Measure the size and direction of this voltage drop and calculate it through the hardware voltage divider. circuit, the resistance value of RX or RY can be obtained. An alarm will be triggered when any resistance value exceeds the limit.

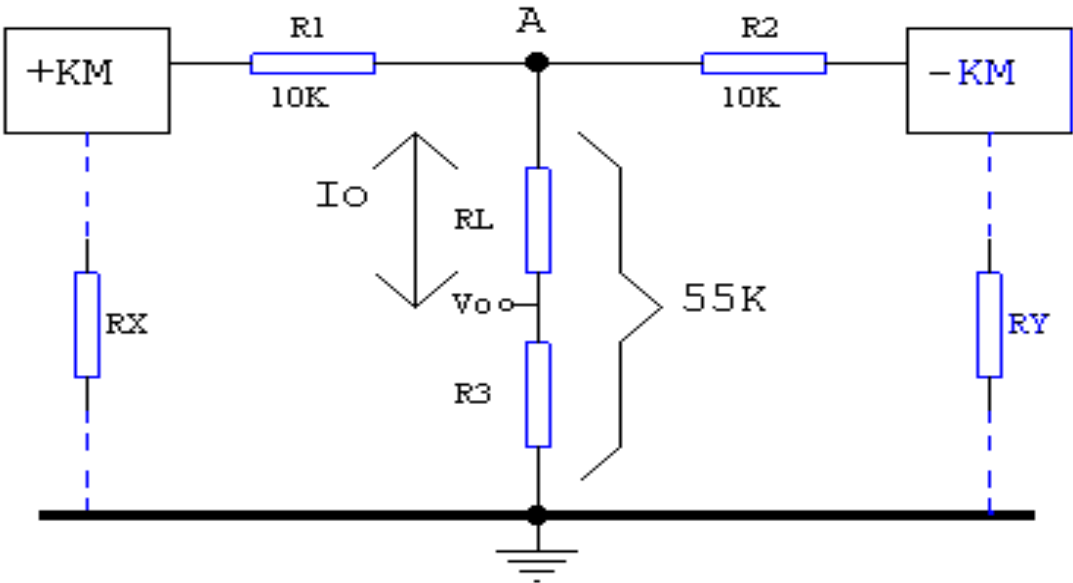

FEATURES

- Positive and negative busbar grounding resistance value direct LCD;
- Alarm resistance threshold online display and direct setting;
- Bridge balance method for resistance measurement;
- Terminals are pluggable for easy maintenance and replacement;
- Various packaging structures, reinforced shell, modular structure, high reliability;

APPLICATIONS

- DC or AC/DC main circuits;
- UPs systems, battery systems;
- IT systems with high leakage capacities;
- DC charging stations for electric vehicles;
- Monitoring the insulation of electrical equipment;
- Supporting use of power transformers, generators, and motors;
- Remote monitoring system, real-time monitoring of insulation conditions;
- Substations, power plants, transmission lines, distribution lines.

2.- TECHNICAL PARAMETERS

Parameters	Symbol	Conditions	Min.	Typical	Max.	Units
Operating voltage range	Vo	Energom-P-2A-220	180	220	300	V
		Energom-P-2A-110	90	110	150	
Power supply	Io	220 Vdc	7		10	mA
Relay capacity	VA	10A@250Vac / 30vdc				A
Resistance measurement range	Ro		0.0		99.9	KΩ
Grounding short-circuit current	Io	Vo=220V			2	mA
Measurement accuracy		Vo=220V		5%		
Alarm setting range	Rs		0.0		20	KΩ
Moves back coefficient		Rs=50KΩ	95%		98%	
Output contact capacity		Inductive $\tau=5mS$			DC220V 0.2A	
		Resistive load			DC220V 2A	

3.- INSTALLATION AND TERMINAL DEFINITION

Dimension: W × H × D = 72 × 72 × 100mm, Hole size: 68 × 68mm.

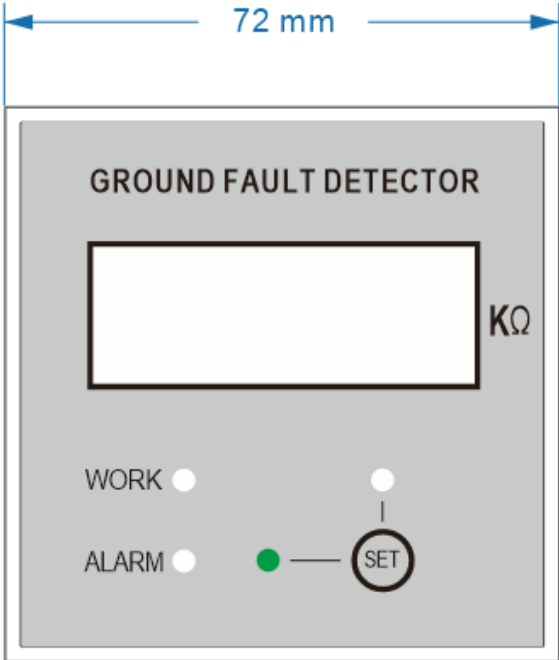

Front view

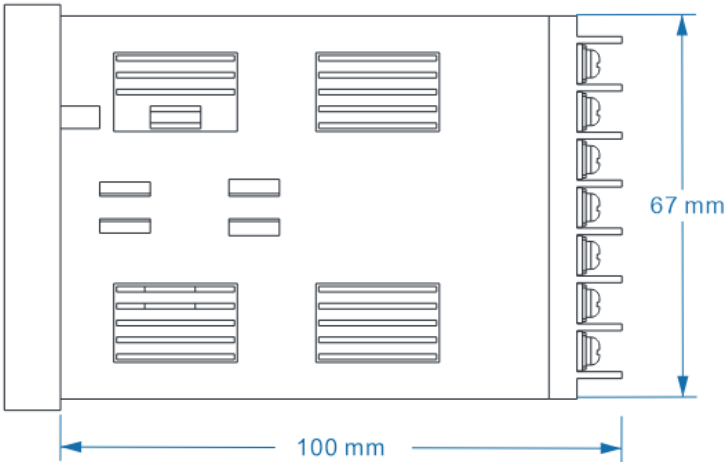

Side view

Terminal definition: Terminal No. 1 is connected to the positive busbar, No. 2 is grounded, No. 3 is connected to the negative busbar, No.4-5 and No.6-7 are two pairs of output alarm dry contacts.

DC Source

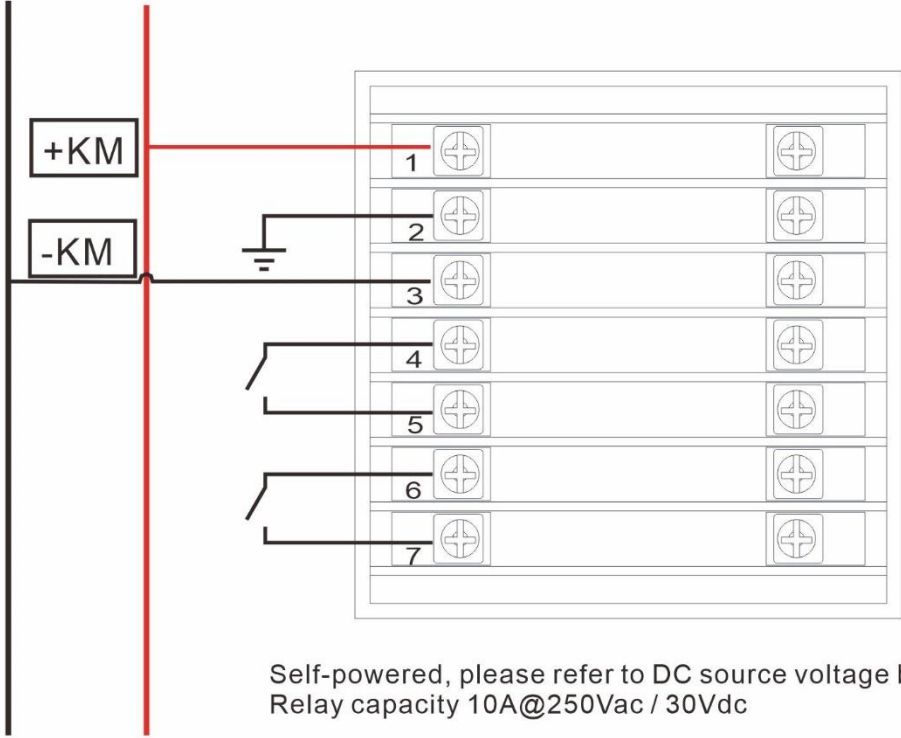

Self-powered, please refer to DC source voltage before order
Relay capacity 10A@250Vac / 30Vdc

4.- OPERATING INSTRUCTIONS

Under normal circumstances, the "WORK" light is on, the "SET" light is off, and the LCD displays the current grounding resistance value. The "+" sign before the number indicates the positive busbar grounding resistance, and the "-" sign indicates the negative busbar grounding resistance.

When the grounding condition is good, when the grounding resistance is greater than the default value of 20K Ω , the highest digit displays a positive or negative "1", indicating that the insulation resistance is infinite at this time, which is the same as the display of electric resistance of ordinary digital multimeters.

When the grounding resistance is less than the set default value of 20K Ω , the display exceeds the limit, the highest digit displays positive or negative "1", and displays the specific resistance value. The red light of "ALARM" is on, and the relay operates to send out an alarm signal.

Note:

When the last ground fault was positive bus grounded, the "+" sign will continue to be displayed on the screen even if the fault recovers; the same is true for negative bus grounded. When there is no grounding, the signs "+" and "-" will be displayed randomly after power on.

Alarm value setting:

Press and hold the SET key, the "SET" light will be on, and the LCD will display the current set value; use a small screwdriver to turn the potentiometer knob on the panel, and the set value will change continuously.

The alarm function will be disabled when the set button is pressed. When in the "measurement" state, avoid blindly adjusting the setting potentiometer, so as to prevent the action threshold from being at an undesired value and affecting the normal alarm.

5.- SAFETY CONSIDERATIONS



All installation specification described at the previous chapters named: **INSTALLATION AND STARTUP, INSTALLATION MODES and SPECIFICATIONS.**

Please note that with the instrument powered on, the terminals could be dangerous to touching and cover opening actions or elements removal may allow accessing dangerous parts. This instrument is factory-shipped at proper operation condition.

- ◆ The device must have a professional installation and maintenance.
- ◆ Any operation of the device, you must cut off the input signal and power;

6.- TECHNICAL SERVICE

For any inquiry about the instrument performance or whether any failure happens, contact to Blue Jay's technical service.