

CPM-70 Multifunction Power Analyzer



Description

CPM-70 multifunction power analyzer provide high accuracy single phase and three-phase energy measuring and displaying, energy accumulating, power quality analysis, data logging and data communication.

CPM-70 series meters are able to measure bidirectional, four quadrants kWh and kVarh.

It provides maximum/minimum records for power usage and power demand parameters. Hardware standard built in a RS485 Modbus communication port , 4 Digital inputs, 2 Relay outputs, LCM and 2 MB flash for data-logging.

In addition , also provide TOU , voltage and current THD, harmonics up to the 31st and auto wiring change via software .

FCC and CE Approved



Applications

- Energy management system
- Power Grid automation
- Factory automation
- Community power monitoring
- Intelligent power panel
- Intelligent green building
- Industrial automation

Ordering Information

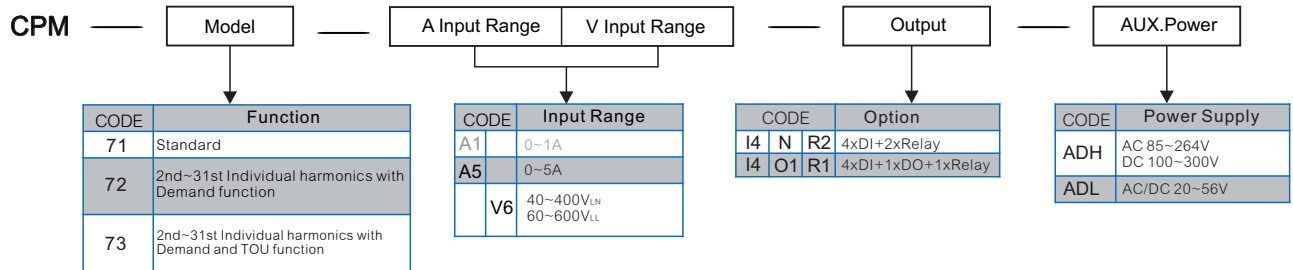

Meter Selection Guide

Features		71	72	73
Voltage	V ₁₂ V ₂₃ V ₃₁ V _{LL,Avg} / V ₁ V ₂ V ₃ V _{LN,Avg}	●	●	●
Current	I ₁ I ₂ I ₃ I _{Avg} I _N	●	●	●
Active Power	Four quadrants P ₁ P ₂ P ₃ Σ P	●	●	●
Reactive Power	Four quadrants Q ₁ Q ₂ Q ₃ Σ Q	●	●	●
Apparent Power	S ₁ S ₂ S ₃ Σ S	●	●	●
Power Factor	PF ₁ PF ₂ PF ₃ PF _{Avg}	●	●	●
Frequency	Hz	●	●	●
Active Energy	Wh Imp Wh Exp Wh Total Wh Net	●	●	●
Reactive Energy	Varh Imp Varh Exp Varh Total Varh Net	●	●	●
Apparent Energy	VAh	●	●	●
THD/Voltage	THD _{V12} THD _{V23} THD _{V31} THD _{V,Avg}	●	●	●
THD/Current	THD _{I1} THD _{I2} THD _{I3} THD _{I,Avg}	●	●	●
Individual harmonic	2nd~31st Individual harmonics		●	●
Demand	Current Demand, Power Demand		●	●
Max. Demand recording	Max. Demand of Current & Power and time stamp		●	●
Max/Min Values	Maximum / Minimum values and time stamp	●	●	●
External Control Input	ECl1 ECl2 ECl3 ECl4	●	●	●
Digital Output	DO1	●	●	●
Relay Output	RO1 RO2	●	●	●
Time of Use	4 seasons, 8 tariff settings per day, Per year or up to 5 years setting			●
Date and Time	Year, Month, Day, Hour, Minute, Second	●	●	●
Run hour	Operating hour , Run hour	●	●	●

Accuracy & Resolutions

PARAMETER	ACCURACY	RESOLUTION	MEASUREMENT RANGE
Voltage	0.2%	0.1V	40.0~400.0Vac(V _{LN})
Current	0.2%	0.001A	1%~120% CT rating current
Neutral Current	1.0%	0.001A	1%~120% CT rating current
Active Power	0.5%	1W	-999999999~999999999W
Reactive Power	0.5%	1Var	-999999999~999999999Var
Apparent Power	0.5%	1VA	0~999999999VA
Power Factor	0.5%	0.001	± 1.000
Frequency	0.1%	0.01Hz	45.00~65.00Hz
Active Energy	0.5%	0.1kWh	0~99999999.9kWh
Reactive Energy	0.5%	0.1kVarh	0~99999999.9kVarh
Apparent Energy	0.5%	0.1kVAh	0~99999999.9kVAh
THD	1.0%	0.1%	0~100.0%
Individual harmonic	1.0%	0.1%	0~100.0%
Unbalance	0.5%	0.1%	0~300.0%

Technical Specification

Electrical Characteristics

Measurement: True RMS
 Sampling: 128 point/Cycle
 Metering system type: 1P2W, 1P3W, 3P3W, (1 ∨ 2 ∨ 3CT) ∨ 3P4W (1 ∨ 3CT) ∨ Balance/Unbalance
 Input range: Voltage:40~400V_{LN} ; 60~600V_{LL}
 PT Primary side ratio: 100~1200000V
 PT Secondary side ratio:50~600V

Current:0~5A, (Optional:0~1A)
 CT Primary side ratio: 5~9999A
 Frequency:45~65Hz
 Voltage:2x rated voltage continuous ; 2500V, 1sec
 Current:2x rated current continuous ; 20x rated current 1sec
 Voltage:<0.2VA ; Current:<0.1 V A

Metering over range:

Input load:

Power Quality

THD:

Total harmonic distortion for voltage and current
 2nd~31st individual harmonics for voltage and current

Individual harmonic:

Relay Output(RO)

Relay contact form: Dual SPST(1a) ; 5A/250Vac ; 5A/30Vdc ;
 Relay action mode: Hi / Lo/Hi.Hold / Lo.Hold /DO
 Set points: Up to 34 parameters of power and Demand for assign
 Digital output mode: Second RO if set to pulse output mode, the maximum frequency is 50Hz

External Control Input (ECI)

Input mode: 4 channels ECI input ; mechanical contact open collector input are available
 Input function: Can set up for DI /Demand reset / Max. Demand reset / Energy values reset / Max. and Min. values reset / Relay reset 0~99 (x8mS) programmable
 Debouncing time:

Digital Output (DO)

Output mode: Open collect(O.C.) ; Output: 30Vdc, 30mA(max)
 Output frequency: 1000Hz(max)
 Pulse divider: 1~9999 (1 Pulse= 0.1kWh; if set 100, 1 Pulse= 10.0kWh)
 Pulse width: 0~5000(x 4mS), 0 is duty cycle 50%
 Energy pulse output: 3200 Pulse/1kWh, Duty cycle 50%

Demand

Calculation method: Slide / Fix

TOU (Time of Use)

4 Seasons: 1~4 seasons per year
 8 Tariff setting: 1~8 each day (For peak, mid peak, off peak per day for billing)
 Parameters of TOU : AE-Imp ∨ AE-Exp ∨ AE-Total ∨ RE- Imp ∨ RE-Exp ∨ RE-Total ∨ SE ∨ SE-Total
 Yearly setting: Tariff setting for 1 year or set up to 5 years

Data Logging

Setting: Load setting from previous saved file or set according to needs. Time interval from 1~32767 for second, minute, hour or day, depend on value record needs.

Memory storage: 2MB Flash ROM

RS485 communication

Protocol: RS485 Modbus RTU mode
 Baud rate: 1200/2400/4800/9600/19200/38400
 Data bits: 8 bits
 Parity: None / Even / Odd
 Stop bit: 1 or 2
 Address: 1~247
 Distance: 1200M max
 Terminate resistor: 120~300Ω/0.25W(typical: 150Ω)

Environmental Characteristics

Operating Temp.: 0~60°C
 Humidity rating: 5~95%RH, Non-condensing
 Temp. coefficient: ≤100 PPM/°C
 Storage Temp.: -10~70°C
 IP Enclosure: Front panel: IEC 529 (IP50) ; Housing: Ip20

Power Supply

Range: ADH: AC 85~264V ; DC 100~300V
 ADL : AC/DC 20~56V
 Power consumption: AC: ≤10VA @ 230V / DC: ≤3W

Mechanical Characteristics

Dimensions: 96mm(W)x96mm(H)x79mm(L)
 Panel cutout: 90mm(W)x90mm(H)
 Material: ABS, Black (with fire-retardant)
 Mounting: Panel mounting
 Weight: ≤450g
 Wire terminal: PA 66 (UL 94V-0)
 Voltage / Current input: AWG: 26~10 / 0.5~4.0mm²
 Screw Torque Value: M3 / 8.0kgf.cm (Max)
 Others input: AWG: 28~16 / 0.5~1.5mm²
 Screw Torque Value: M2 / 2.04kgf.cm (Max)

Safety

Isolation: AC 2KV, 50/60Hz, for 1 min, Between Power / Input / Output / Case
 Insulation resistance: ≥ 100MΩ @ 500V_{dc}
 EMC: EN61326-1:2013
 EN61000-3-2:2014
 EN61000-3-3:2013
 LVD: EN61010-1:2010

Accuracy of energy

Active energy 0.2s Class (IEC62053-22:2003)
 Reactive energy 2.0 Class (IEC62053-23:2003)

Front panel

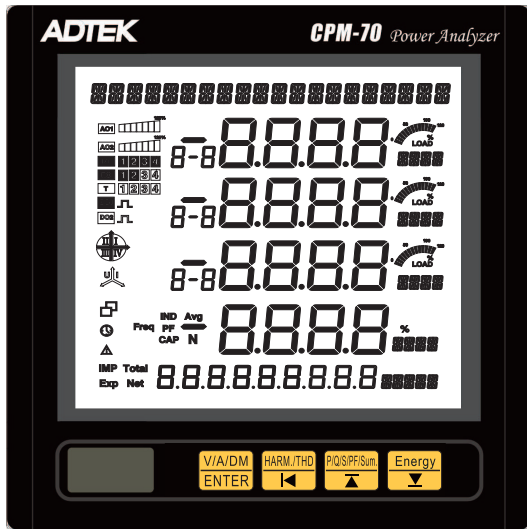

Display: LCD 65(W)x61(H)mm ; White backlight
 Backlight delay time : 0~15 min ("0" is always on)

Description: Twenty digits in the top of display area: Display mode indication.
 Four line of 8 digits in the metering area : Display metering data such as voltage \ current \ power \ power factor \ frequency \ unbalance \ etc.
 Four line of 8 digits in the metering area : Display metering data unit.
 Three line 8-8 digits: 1, 2, 3 for 3 phase ; 1-2, 2-3, 3-1 for 3 phase line to line.
 Nine 8 and five 8 digits: Display energy data and unit.
 Also display real time o'clock.

Dimensions

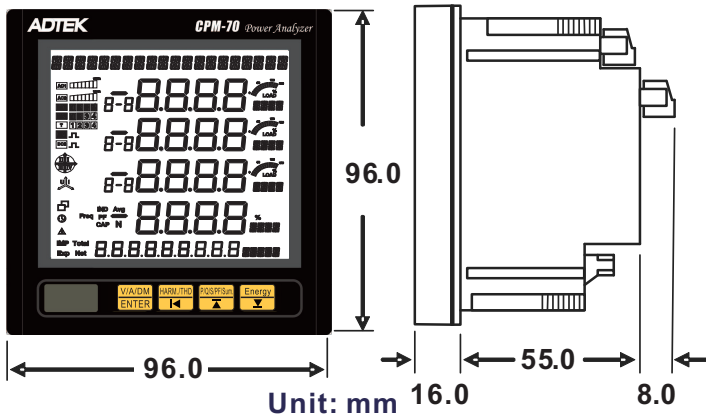

Connection diagram

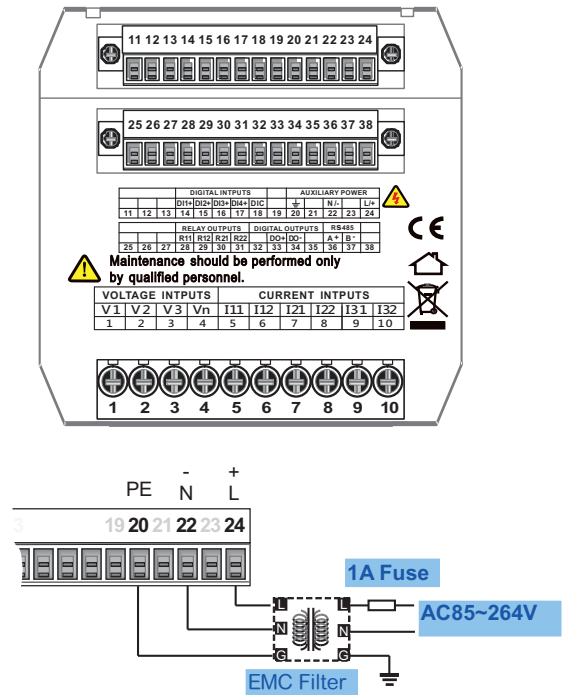

RS485 Communication port

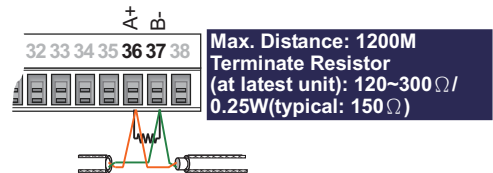

Installation

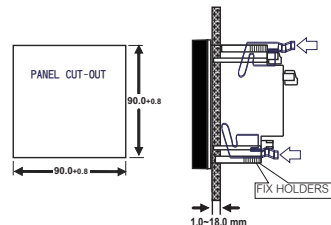

Voltage and current connection

1P2W

w/o PT/ 1CT

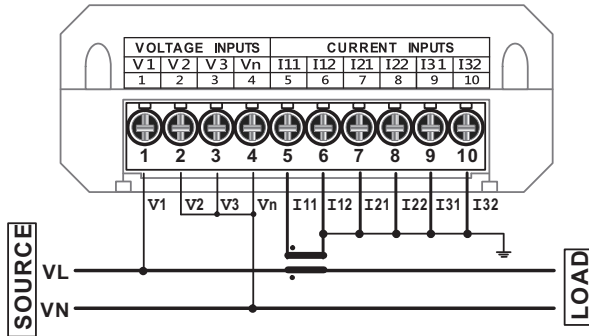

1P3W

w/o PT/ 2CT

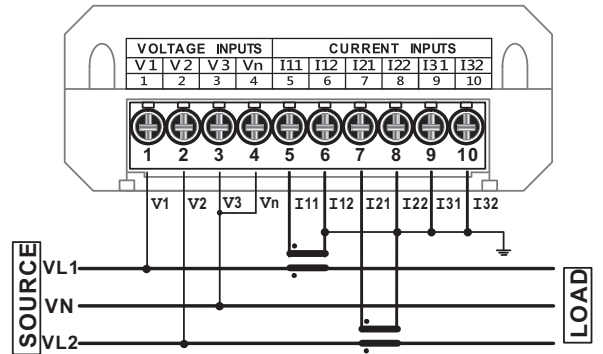

3P3W

2PT/ 3CT

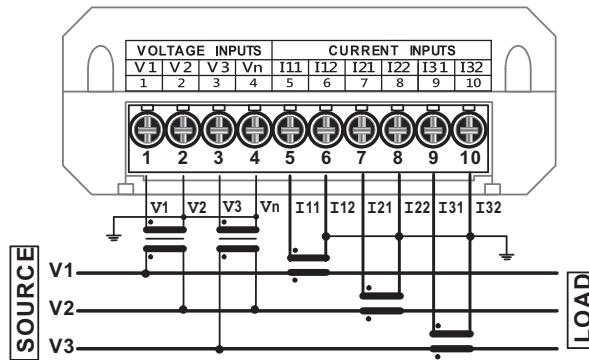

w/o PT/ 3CT

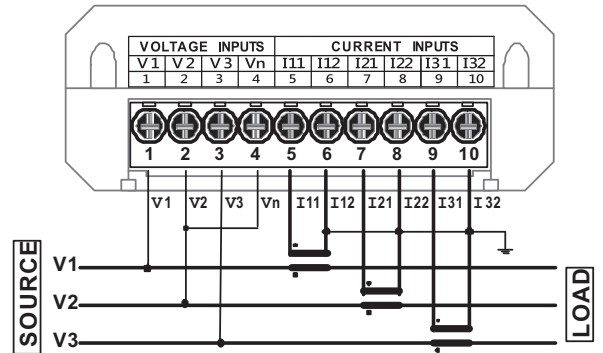

2PT/ 2CT

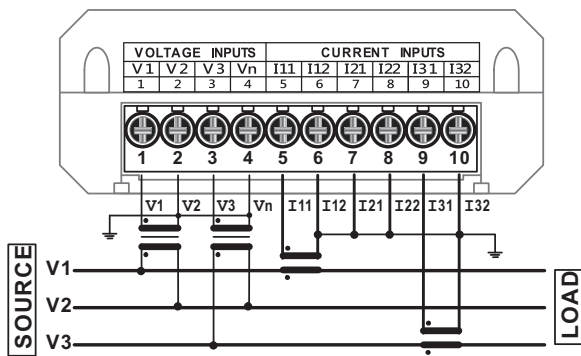

w/o PT/ 2CT

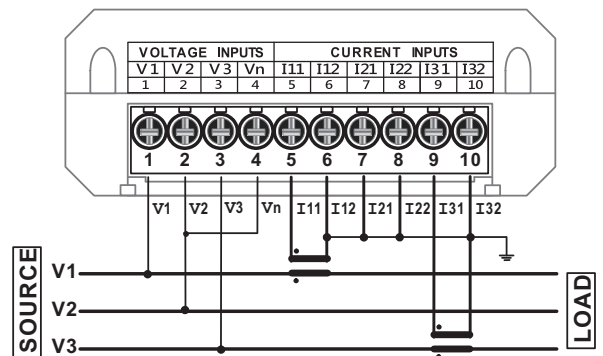

2PT/ 1CT

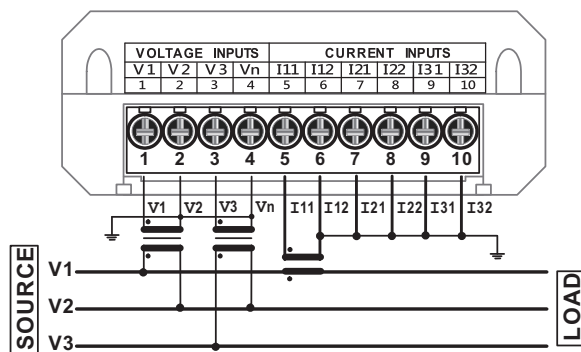

w/o PT/ 1CT

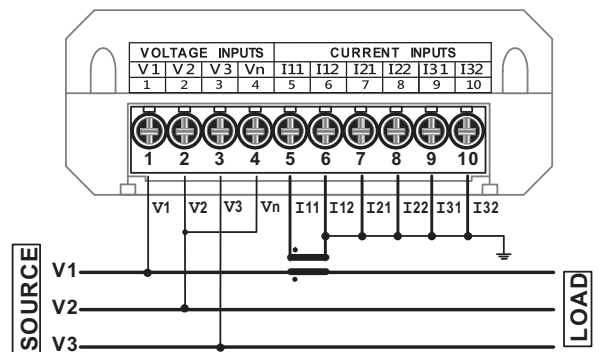

CPM-70

2PT/ 2CT

※This CT connection is available use for Inverter load or normal load situation

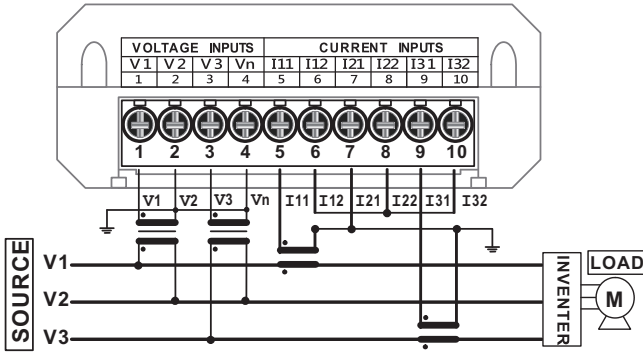

w/o PT/ 2CT

※This CT connection is available use for Inverter load or normal load situation

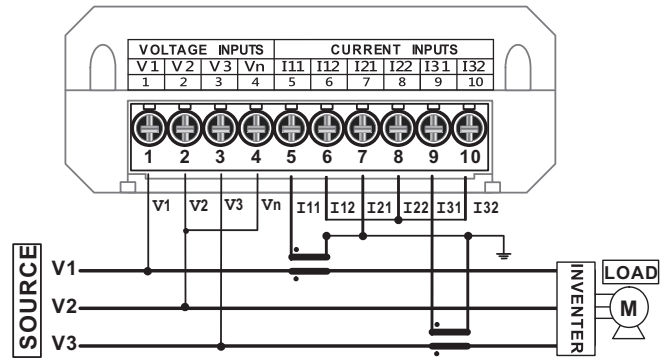

3P4W

3PT/ 3CT

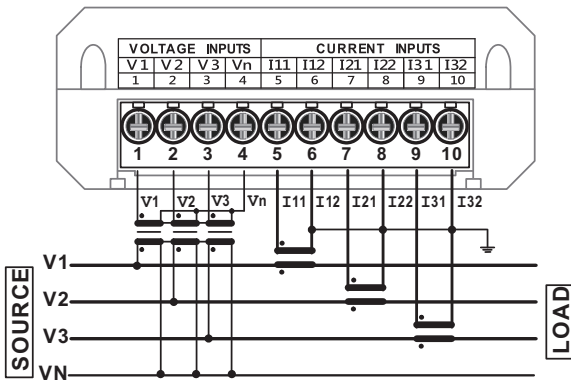

w/o PT/ 3CT

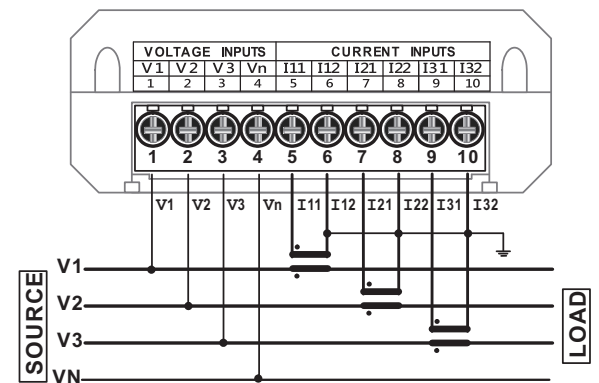

3PT/ 1CT

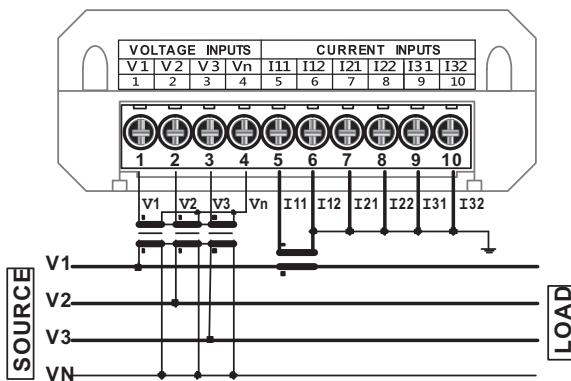

w/o PT/ 1CT

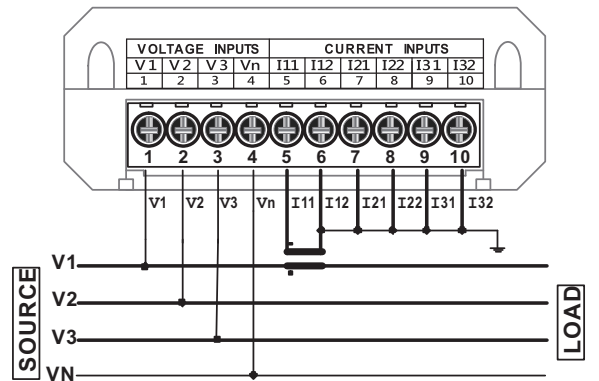

External Control Input (ECI)

Wire:AWG22~16(0.5~1.3mm²)

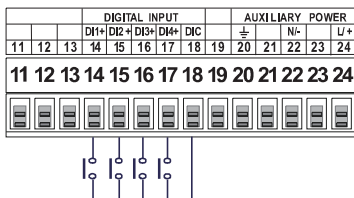

Relay Output(RO)/ Digital Output (DO)

Wire:AWG22~16(0.5~1.3mm²)

