

| | | Unit | Pa | mmH ₂ O | mbar | inWG | mmHG | daPa | KPa | hPa |
|------------------|-------|--------|---------|--------------------|-------|-------|---------|--------|--------|-----|
| 4 3 2 1 | FM116 | 10.0 | 1.00 | 0.100 | / | / | 1.00 | / | 0.100 | |
| | FM110 | 100 | 10.0 | 1.00 | 0.40 | 0.75 | 10.0 | 0.100 | 1.00 | |
| | FM112 | 1,000 | 100.0 | 10.00 | 4.00 | 7.50 | 100 | 1.000 | 10.00 | |
| 4 3 2 1 | FM116 | 25.0 | 2.50 | 0.250 | / | / | 2.50 | / | 0.250 | |
| | FM110 | 250 | 25.0 | 2.50 | 1.00 | 1.87 | 25.0 | 0.250 | 2.50 | |
| | FM112 | 2,500 | 250.0 | 25.00 | 10.00 | 18.75 | 250.0 | 2.500 | 25.00 | |
| 4 3 2 1 | FM116 | 50.0 | 5.00 | 0.500 | / | / | 5.00 | / | 0.500 | |
| | FM110 | 500 | 50.0 | 5.00 | 2.00 | 3.750 | 50.0 | 0.500 | 5.00 | |
| | FM112 | 5,000 | 500.0 | 50.00 | 20.00 | 37.50 | 500.0 | 5.000 | 50.00 | |
| 4 3 2 1 | FM116 | 75.0 | 7.50 | 0.750 | / | / | 7.50 | / | 0.750 | |
| | FM110 | 750 | 75.0 | 7.50 | 3.00 | 5.62 | 75.0 | 0.750 | 7.50 | |
| | FM112 | 7,500 | 750.0 | 75.00 | 30.00 | 56.20 | 750.0 | 7.500 | 75.00 | |
| 4 3 2 1 | FM116 | 100.0 | 10.00 | 1.000 | / | / | 10.00 | / | 1.000 | |
| | FM110 | 1,000 | 100.0 | 10.0 | 4.00 | 7.50 | 100.0 | 1.000 | 10.00 | |
| | FM112 | 10,000 | 1,000.0 | 100.00 | 40.00 | 75.00 | 1,000.0 | 10.000 | 100.00 | |

Full range/Central zero (take 0~1,000Pa as an example)

To set the type of measuring range by adjusting the pressure range switch as indicated below

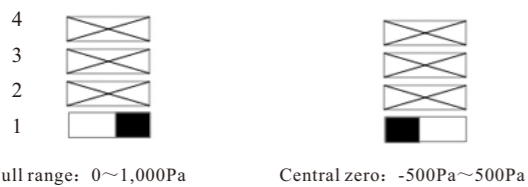

⚠ Please follow carefully the combinations above the Dial-up switch. If the combination is wrongly done, the following message will appear on the display as "Err". In that case, you have to unplug the transmitter, place the Dial-up switches correctly and then power the transmitter up

② Unit setting

Set the pressure unit by adjusting the dial up switches referring to following combination

| | Pa | mmH ₂ O | mbar | inWG |
|-------------|----|--------------------|------|------|
| Combination | | | | |
| Combination | | | | |

③ Auto zero function setting

Dial the switch 1 to activate or deactivate the auto zero function when powering up (the transmitter will be auto zeroed when activate this switch and vice versa)

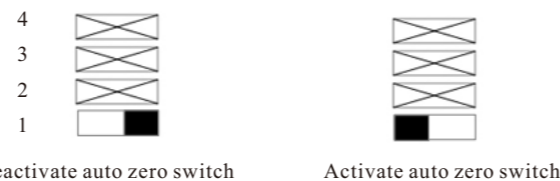

④ Response time setting

Set the response time by adjusting the time response dial up switches referring to following combination

| | 0.5s | 1s | 2s | 4s |
|-------------|------|----|----|----|
| Combination | | | | |

⑤ RS-485 model setting

We included the RS-485 communication function in time response dial up switches. By dial up the switch 1 and 2 in following combination to change the baud rate either in 19200 or 9600 (Only workable for RS485 differential transmitter)



In the Figure 4 there are a set of resistor jump which could be connected for reducing signal interference when the communication distance above 300 meters.

Electrical connection

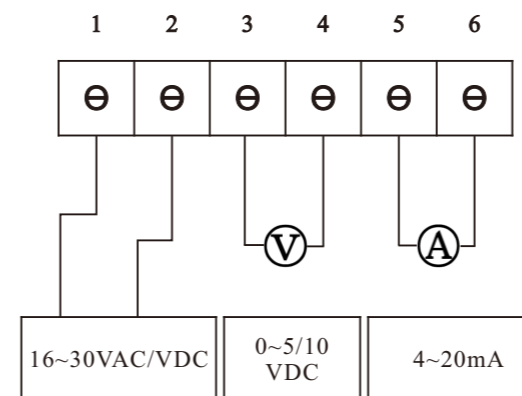
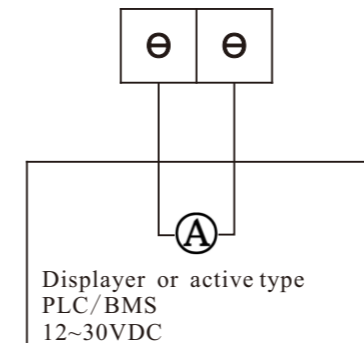
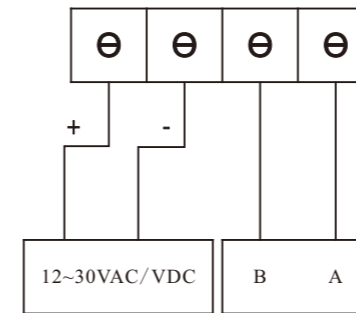

- 1、Power Positive : VAC/VDC L
- 2、Power Negative : VAC/VDC N
- 3、Output signal: GND
- 4、Voltage output signal: V_{out}
- 5、Output signal: GND
- 6、Current output signal: I_{out}

0~5VDC/0~10VDC and 4~20mA 6-wire

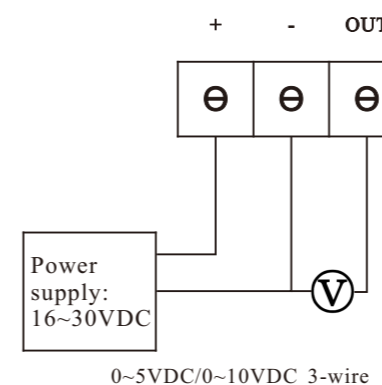

Remark: Unscrew the 4 screws from the back cover, then take out the rubber cap, then connect the terminal and cable through the cable gland, then tighten the cable gland and cover the back cover

Mounting

To mount the transmitter, mount the ABS plate on the wall (drilling: Ø6mm, depth 30mm, screws and pins are supplied) Insert the transmitter on the fixing plate (see A on the drawing) Rotate the housing in clockwise direction until you hear a 'click' which confirms that the transmitter is correctly installed.

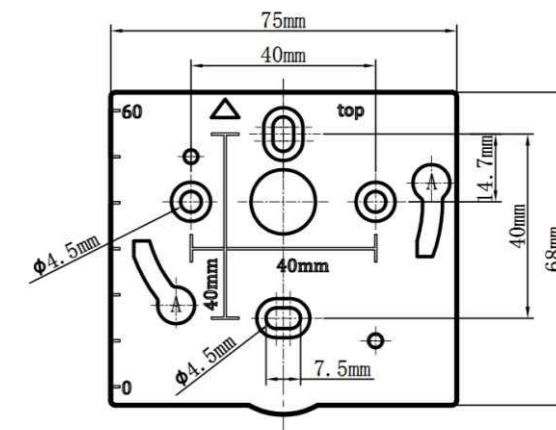

Maintenance

Please avoid any aggressive solvent and protect the transmitter and its probes from any cleaning product containing formalin, that may be used for cleaning rooms and ducts.

Chargeable Accessories

- Power adapter
- Connection tube

Common problem and solutions

- 1、The display range or units do not tally with the Settings.
 - ① dial the code switch is not in place, the electricity to restart the redial later.
- 2、Pressure pressure showed no change or the output value (display of 0 or FULL), or change is not allowed.
 - ① whether the load pressure over blasting pressure directly blunt bad core body;
 - ② whether there is corrosive or use media. And the purchased product applicable medium exist discrepancy (existing micro differential pressure transmitter are for no corrosive gas);
 - ③ check whether there is any foreign bodies blocked on inlet hose (particulate matter or water) or leakage;
 - ④ using the environment temperature is beyond compensation temperature range (micro differential pressure transmitter temperature compensation range - 10~60 °C);
 - ⑤ with and without the pressure to zero wrong operation, such as there is no input in determining the state of stress under the reset again;
 - ⑥ have corrosive Settings button of wrong operation (Settings button to prevent wrong operation mechanism, namely the set point pressure value must be increasing from small to big to finally set up successful, needs to be in high precision pressure source under the calibration set, don't recommend customer to calibration, such as the deviation caused by the calibration operation, must be returned to the factory heavy school).
- 3、Pressure normal value, no output analog or analog output is not allowed.
 - ① check the output line connection is normal;
 - ② three wire system output is to detect transducer with control instrument is normal (i.e., ground wire must be connected to);
 - ③ check the load resistance to choose proper.
- 4、The zero pressure value drift slightly.
 - ① clear operation after drift stability.

If the above method cannot eliminate the fault, contact the manufacturer!