



**TEMPERATURE
and HUMIDITY
TRANSDUCER
P19 TYPE**



USER'S MANUAL



Contents

1. APPLICATION	5
2. TRANSDUCER SET	5
3. BASIC REQUIREMENTS, OPERATIONAL SAFETY	6
4. INSTALLATION.....	6
4.1. Overall dimensions and working position	6
4.2. Electrical connections.....	7
4.3. Assembly	8
5. SERVICING	10
5.1. Messages after supply is switched on.....	10
5.2. Functions of the P19 transducer	10
5.2.1. Calculated values	11
5.2.2. Default parameters	12
6. MODBUS PROTOCOL ON RS-485 SERIAL PORT	12
6.1. Serial interface connection	12
6.2. Description of the MODBUS protocol	13
6.3 Description of implemented MODBUS functions.....	13
6.4 Register map	18
6.5 Read/Write registers.....	19
6.6 Read only registers	21
7. EMERGENCY RESTORATION OF RS-485 PARAMETERS.....	22
8. TECHNICAL DATA	23
9. ORDERING CODE.....	25

1. APPLICATION

The P19 transducer is device destined for the continuous measurement and conversion of relative humidity and ambient temperature into a digital form (protocol MODBUS RS-485). The transducer is fixed on a wall. The programming of the transducer is possible by means of the RS-485 interface.



Fig. 1. View of the P19 transducer.

2. TRANSDUCER SET

The delivered controller set is composed of:

- 1. transducer P19 1 pc
- 2. user's manual 1 pc
- 3. guarantee card..... 1 pc

3. BASIC REQUIREMENTS, OPERATIONAL SAFETY

In the security scope, the transducer meets the requirements of the EN 61010 -1 standard.



Remarks concerning the operator safety:

- All operations concerning transport, installation, and commissioning as well as maintenance must be carried out by qualified, skilled personnel.
- Before switching the transducer on, one must check the correctness of connections to the network.
- The device is destined to be installed and used in industrial electromagnetic environment conditions.

When unpacking the P19 transducer, please check whether the type and version code on the data plate correspond to the order code.

4. INSTALLATION

4.1. Overall dimensions and working position

The P19 transducer is designed to be mounted on a wall by means of a screw connection. Transducer housing is assembled of two parts: front part and back part. The transducer has screw connectors placed inside the transducer, which enable the connection of external wires of 1 mm² cross-section.

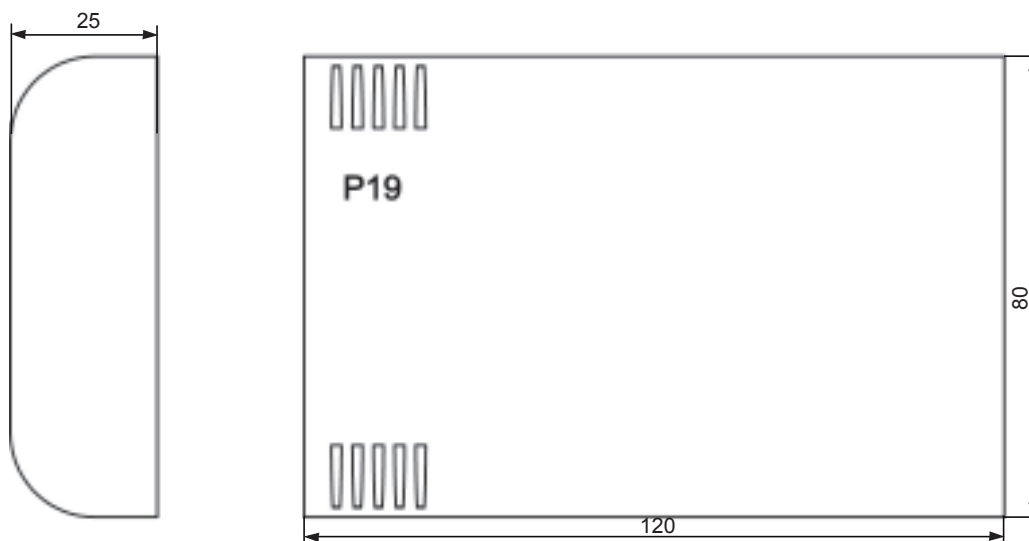

Fig. 2. Overall dimensions of the P19 transducer and correct working position

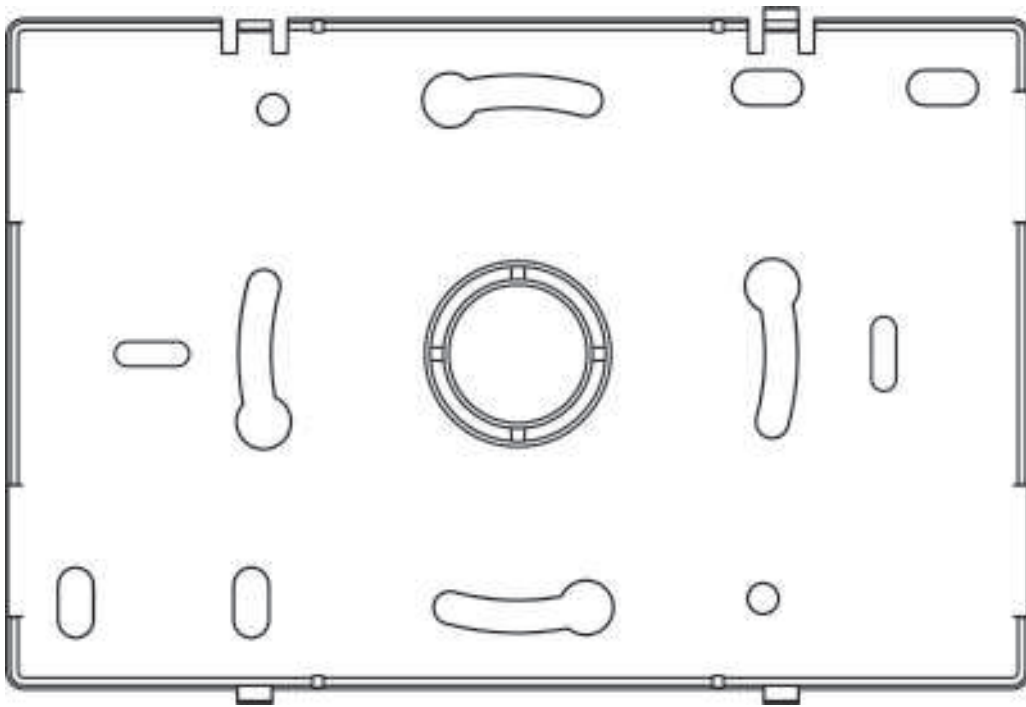

Fig. 3. Lay-out of assembly holes in back part of housing

4.2. Electrical connections

The P19 transducer has 4 connecting terminals to which there is access after removing the front part of the transducer housing.

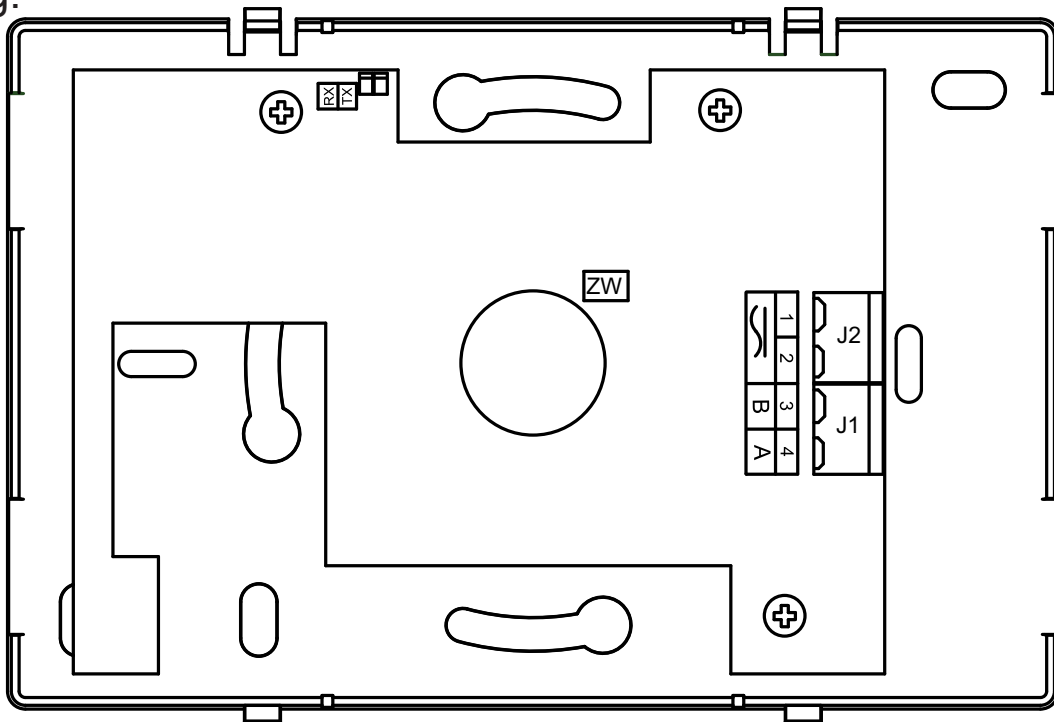

Fig 4. Marking of terminals for the connection of external signals

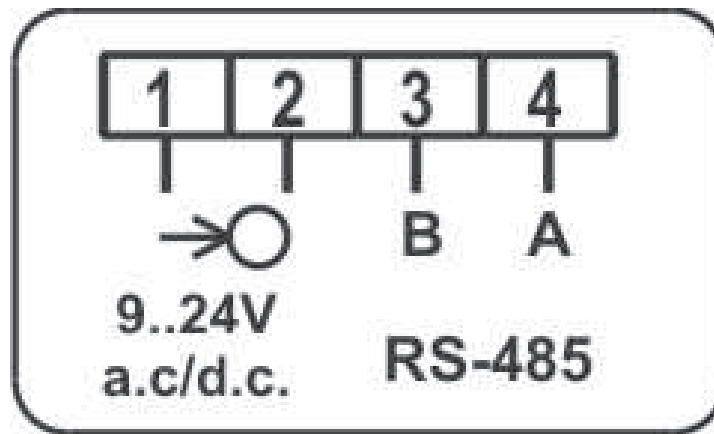

Fig. 5. Way of electrical signal connection

Transducer is equipped with two LED indicator: RX (green color) , TX (red color), which indicates the state of RS-485 communication lines. Indicators works only first 60 sec after power is on or after switching “ZW” jumper (section 7).

4.3. Assembly

On the beginning one must separate front part of housing from back part of housing with printed circuit board using flat screwdriver as shown on Fig. 6.

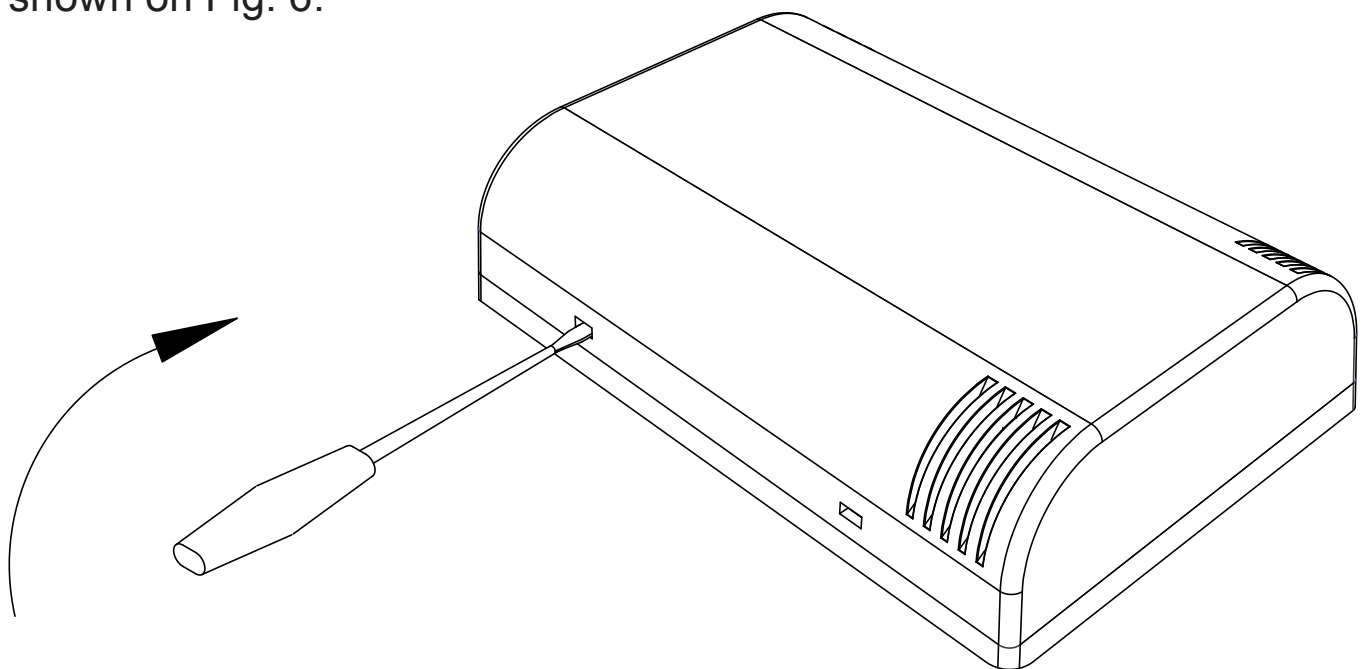

Fig. 6. Disassembly housing method

Back part of housing is equipped with hole at the middle of housing through which electrical cords should be passed. Then back part of housing should be screwed on to the wall. Electrical cords should be passed through the hole on the printed circuit board (Fig. 7) and connected to the screw connectors with the right way (Fig. 5)

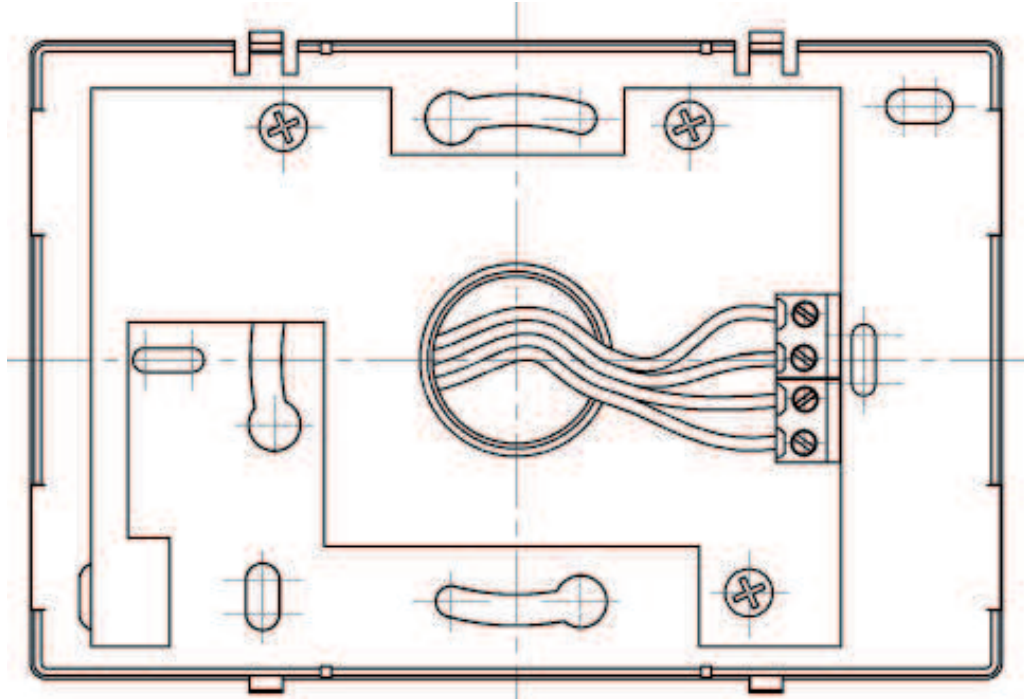

Fig. 7. The way of assembly electrical cords

After connecting cords and pushing the front part of housing transducer is ready to work.

To connect the input signals in an environment with high interference, one must apply shielded wires. The shield must be connected to the nearest PE point from the feeder side.

5. SERVICING

After connecting cords, closing the housing, and connecting to the supply, the transducer is ready to work with manufacturer's settings (table 2). The transducer can be programmed through the RS-485 interface. One can program following parameters in the transducer:

- communication parameters
- averaging time of the measurement

There is the possibility to connect the transducer through another transmission media, like: ETHERNET, USB, using LUMEL S.A.'s converters.

5.1. Messages after supply is switched on

After connecting external signals and switching the supply on, the transducer indicates its ready to work by switching on two LED indicators RX (green color) i TX (red color). After about 5 seconds, the transducer automatically switches to the mode in which it measures and converts into the digital value.

5.2. Functions of the P19 transducer

- measurement of ambient temperature and relative humidity,
- calculation of chosen physical quantities (dew-point temperature, absolute humidity),
- memory storage of maximal and minimal values for each of the measured and calculated value,
- programming of the measurement averaging time,
- RS-485 interface servicing in the MODBUS protocol, in RTU mode.

5.2.1. Calculated values

Based on measured temperature and relative humidity the P19 transducer calculates dew-point and absolute humidity from the following relations.

$$DP \rightarrow \text{dew point: } DP = \frac{T_n}{\frac{m}{\log \left(P_{ws} \cdot \frac{RH}{10000 \cdot A} \right)} - 1}$$

$$AH \rightarrow \text{absolute humidity: } AH = 2.1668 \cdot \frac{P_{ws} \cdot RH}{100 \cdot (T + 273.2)}$$

where:

$T \rightarrow$ measured temperature [oC]

$RH \rightarrow$ measured relative humidity [%]

$DP \rightarrow$ dew-point temperature [oC]

$P_{ws} \rightarrow$ pressure of the saturated water vapor
(water vapor pressure) [mbar]

$AH \rightarrow$ absolute humidity [g/m³]

Table 1

Coefficients used for the dew-point calculations			
T [°C]	A	m	Tn
< 0	6.119866	7.926104	250.4138
0 ... 50	6.1078	7.5	237.3
50 ...100	5.9987	7.3313	229.1

5.2.2. Default parameters

Table 2 shows the default parameters of P19 transducer. These settings can be restored using the RS-485 interface by writing into the 4009 register the value „1”.

Table 2

Parameter description	Parameter address	Default value
Address	4001	1
Baud rate	4002	9600
Mode	4003	RTU 8N2
Averaging time	4005	30 [s]

When standard communication parameters have been changed and the new configuration has been lost, one can set temporary parameters by switching the jumper marked with the symbol “ZW” (section 7).

6. MODBUS PROTOCOL ON RS-485 SERIAL PORT

Digital P19 transducers are equipped with serial RS-485 link port with implemented MODBUS protocol to enable digital communication between computer systems and other devices which have MODBUS Master functions implemented. The implemented protocol is in compliance with the PI-MBUS-300 Rev G Modicon Company specification.

6.1. Serial interface connection

Standard RS-485 port allows direct connection of up to 32 devices on a single serial link with a length of 1200 m (at a baud rate of 9600 b/s). To connect more devices it is necessary to use additional intermediate-separating devices.

Interface line location are shown in the figure 5. To obtain a correct transmission it is necessary to connect the A and B line parallel with their counterparts in other devices. To connect to the PC, the RS-485 interface card or the converter, e.g. PD10 is required.

6.2. Description of the MODBUS protocol

The implemented protocol is in compliance with the PI-MBUS-300Rev G Modicon Company specification. Parameters of the transducer serial link :

transducer address	1..247
baud rate:	4800, 9600, 19200, 38400, 57600 [b/s]
working modes:	RTU: 8N2, 8E1, 8O1, 8N1
maximal response time:	500 ms

The configuration of serial link parameters consists on settlement of baud rate, device address and protocol (working mode).

Note: Each transducer connected to the communication network must have:

- unique address, different from other devices connected to the network,
- the same baud rate and information unit type (working mode).

6.3 Description of implemented MODBUS functions

Functions of the Modbus protocol implemented in P19 transducer::

- 03 (03h) – Read Holding Registers
- 04 (04h) – Read Input Registers
- 06 (06h) – Write Single Register

- 16 (10h) – Write Multiple registers
- 17 (11h) – Report Slave ID.

Read Holding Registers (code 03h)

Example 1. Reading two float(32 bits) registers, first register address is 1D4Dh (7501) , register values (7501, 7502): 25.68, 20.25.

Request:

Table 3

Device address	Function	Register address		Number of registers		CRC
		B1	B0	B1	B0	
01h	03h	1Dh	4Dh	00h	02h	5270h

Response:

Table 4

Device address	Function	Number of bytes	1DB0h (7501)				1DB1h (7502)				CRC
			B3	B2	B1	B0	B3	B2	B1	B0	
01h	03h	08h	41h	CDh	70h	A4h	41h	A2h	00h	00h	83D0h

Example 2 . Reading two float 32-bit registers (7501,7502) located in 2x2 following 16-bit registers (7002, 7003, 7004, 7005), first register address is 1B5Ah (7002) – 32-bit register values : 25.68, 20.25.

Request:

Table 5

Device address	Function	Register address		Number of registers		CRC
		B1	B0	B1	B0	
01h	03h	1Bh	5Ah	00h	04h	62FEh

Response:

Table 6

Device address	Function	Number of bytes	Register value 1B5Ah (7002)		Register value 1B5Bh (7003)		Register value 1B5Ch (7004)		Register value 1B5Dh (7005)		CRC
			Register 7501 (32 bit) value				Register 7502 (32 bit) value				
			B3	B2	B1	B0	B3	B2	B1	B0	
01h	03h	08h	41h	CDh	70h	A4h	41h	A2h	00h	00h	83D0h

Example 3. Reading two float 32-bit registers (7501,7502) located in 2x2 following 16-bit registers (6002, 6003, 6004, 6005), first register address is 1772h (6002) - 32-bit register values : 25.68, 20.25.

Request:

Table 7

Device address	Function	Register address		Number of registers		CRC
		B1	B0	B1	B0	
01h	03h	17h	72h	00h	04h	E1A6h

Response:

Table 8

Device address	Function	Number of bytes	Register value 1B5Ah (7002)		Register value 1B5Bh (7003)		Register value 1B5Ch (7004)		Register value 1B5Dh (7005)		CRC		
			Register 7501 (32 bit) value						Register 7502 (32 bit) value				
			B1	B0	B1	B0	B3	B2	B1	B0			
01h	03h	08h	70h	A4h	41h	CDh	00h	00h	41h	A2h	E411h		

Write Single Register (code 06h)

Example 4. Writing value “3” to the register 0FA1h (4001)

Request:

Table 9

Device address	Function	Register address		Number of registers		CRC
		B1	B0	B1	B0	
01h	06h	0Fh	A1h	00h	03h	983Dh

Response:

Table 10

Device address	Function	Register address		Number of registers		CRC
		B1	B0	B1	B0	
01h	06h	0Fh	A1h	00h	03h	983Dh

Write Multiple registers (code 10h)

Example 5. Writing value “3” and “4” to registers FA1h (4001) and FA2h (4002)

Request:

Table 11

Device address	Function	Register address		Number of registers		Num-ber of bytes	Register value (4001)		Register value (4002)		CRC
		B1	B0	B1	B0		B1	B0	B1	B0	
01h	10h	0Fh	A1h	00h	02h	04h	00h	03h	00h	04h	8828h

Response:

Table 12

Device address	Function	Register address		Number of registers		CRC
		B1	B0	B1	B0	
01h	10h	0Fh	A1h	00h	02h	133Eh

Report Slave ID (code 11h)

Example 6. Report slave ID

Request:

Table 13

Device address	Function	CRC
01h	11h	C02Ch

Response:

Table 14

Address	Function	Number of bytes	ID	Device state	Variable bytes depending on device firmware ver. And serial number (neg. ver. 0.95, serial number. 13040001)	CRC
01h	11h	08h	D0h	FFh	00h 95h 40h 01h 80h 0Dh	DFC3h

6.4 Register map

In the P19 transducer the data is stored in 16- and 32-bit registers. The process variables and parameters of the device are stored in the different address space depending on the variable type. The bits in the 16-bit registers are numbered from the least significant to the most significant (b0 ... b15). The 32-bit registers (4 Bytes) contain floating-point values in IEEE-754 standard. Bytes sequence: B3 B2 B1 B0 – the most significant byte is sent as the first one. 16-bit registers which represents 32-bit values on a two following registers are multiplied at different address field with different bytes (word) order. Registers 6000...6024 (B1, B0, B3, B2) , Registers 7000...7024 (B3, B2, B1, B0). Register map of the P19 transducer is shown in Table 15.

Note:

All the given addresses are physical addresses. In some computer programs logical addressing is applied, then the addresses should be increased by 1.

Table 15

Address range	Value type	Description
4000 - 4011	integer (16 bits)	The value is located in the 16-bit register
6000-6024	float (32 bits)	The value is located in two following 16-bit registers. Registers contain the same data as 32-bit registers from the area 7500-7512. Registers are readout type only. Byte order (B1, B0, B3, B2)
7000-7024	float (32 bits)	The value is located in two following 16-bit registers. Registers contain the same data as 32-bit registers from the area 7500-7512. Registers are readout type only. Byte order (B3, B2, B1, B0)
7500-7512	float (32 bits)	The value is located in the 32-bit register. Registers contain measured and calculated data by the transducer. Registers are readout type only. Byte order (B3, B2, B1, B0)

6.5 Read/Write registers

Table 16

Address	Name	Read(r)/ Write (w)	Range	Description	
4000	Identifier	r	208	Identifier of the P19 transducer	
4001	Address	r/w	1...247	Device address	
4002	Baud rate of the RS-485 link	r/w	0...5	Value	Description
				0	4800 bit/s
				1	9600 bit/s
				2	19200 bit/s
				3	38400 bit/s
				4	57600 bit/s
4003	Transmission mode of the RS-485 link	r/w	0...3	Value	Description
				0	RTU 8N1
				1	RTU 8N2
				2	RTU 8E1
				3	RTU 8O1
4004	Acceptation of RS-485 link parameter changes	r/w	0...1	Value	Description
				0	no changes
				1	acceptation of changes
4005	Averaging time	r/w	6...3600	Measurement averaging time [s]	

4006	Erasing of extremes	r/w	0...1	Value	Description
				0	no changes
				1	Erasing of min and max value
4007	Status register	r/w	-32768... 32767	Transducer status. Describe current state and device configuration. Bits representing specific events. Value bit '1' means that specific event occurred.	
				Bit15	Supply reset, writing value -32768 (8000h) clears status bit
				Bit14	Calibrations parameters error
				Bit13	Incorrect transducer parameters – new parameters required
				Bit12	unused
				Bit11	unused
				Bit10	Min/max erasing status, writing value 1024 (400h) clears status bit
				Bit9	Temporary communication parameters set (short circuit „ZW” jumper)
				Bit8	unused
				Bit7	Communication with sensor error
				Bit5,6	unused
				Bit3,4	unused
				Bit2	Exceeding of measurement averaging time
				Bit1	unused
Bit0	unused				

4008	Firmware ver.	r	1...999	Firmware version x100	
4009	Restore default parameters	r/w	0...1	Value	Description
				0	no changes
				1	Force restoring default parameters (value of register will automatically change to "0")
4010	reserved				
4011	reserved				

6.6 Read only registers

Table 17

Value is place in two following 16-bit registers, Those register have the same value like 32-bit register from range 7500....	Value placed in 32-bit registers	Name	Read (r)/ Write (w)	Unit	Description
7000/6000	7500	ID	w	-	P19 identifier
7002/6002	7501	T	w	°C	Measured temperature
7004/6004	7502	RH	w	%	Measured relative humidity
7006/6006	7503	DP	w	°C	Calculated dew point
7008/6008	7504	AH	w	g/m ³	Calculated absolute humidity
7010/6010	7505	min T	w	°C	Min. measured temperature

7012/6012	7506	max T	w	°C	Max. measured temperature
7014/6014	7507	min RH	w	%	Min. measured relative humidity
7016/6016	7508	max RH	w	%	Max. measured relative humidity
7018/6018	7509	min DP	w	°C	Min. calculated dew point
7020/6020	7510	max DP	w	°C	Max. calculated dew point
7022/6022	7511	min AH	w	g/m ³	Min. calculated absolute humidity
7024/6024	7512	max AH	w	g/m ³	Max. calculated absolute humidity

7. EMERGENCY RESTORATION OF RS-485 PARAMETERS

When standard communication parameters have been changed and the new configuration has been lost, one can set temporary RS-485 parameters by switching jumper marked with the symbol „ZW” (Fig. 4.) Temporary RS-485 parameters are shown below:

- address 247
- baud rate 9600 kb/s
- mode RTU 8N2

The changes of parameters must be made before removing the jumper, otherwise the device will return to its previous configuration.

8. TECHNICAL DATA

Basic parameters:

- relative humidity range	0...100 % ¹
- relative humidity measurement accuracy	±3% in range 10...90% ±5% for the remaining range
- hysteresis of measuring relative humidity	± 1%
- temperature range	- 20...60 °C ²
- temperature measurement accuracy	±0.6°C in range 10...40° C ±1.0°C for the remaining range
- calculated values	absolute humidity (a) [g/m ³] dew point (Td) [°C]

RS-485 interface:

- protocol	MODBUS slave
- baud rate	4800, 9600, 19200, 38400, 57600 bit/s
- mode	RTU: 8N2, 8E1, 8O1, 8N1
- maximal response time	500 ms

Rated operating conditions:

- supply voltage	9...24 V a.c. / d.c.
- power consumption	< 0.3 VA
- ambient temperature	- 20...23...60 °C
- storage temperature	- 30...23...85 °C
- relative humidity:	< 95% ¹
- warm-up time	<15 min.
- insured protection grade ensured by the housing	IP 20
- mounting	on the wall
- weight:	<0.2 kg
- dimensions	120 x 80 x 25 mm

working position:

according Fig. 2.

Galvanic isolation

- between supply and RS-485 interface 1 kV

Electromagnetic compatibility:

- disturbance immunity

acc. to EN 61000-6-2

- disturbance emission

acc. to EN 61000-6-4

Security requirements acc. to EN 61010-1

- installation category

III

- pollution grade

2

- phase-to-earth working voltage

50V

- altitude above sea level

< 2000m

- ¹ - In case of condensation of water vapor on the sensor surface, the error measurement does not exceed the basic error till the moment of drying up the sensor structure.
- ² - The absolute temperature measurement range is -30...85°C, but beyond the basic range, the measurement class is not guaranteed.

9. ORDERING CODE

Table 18

P19 -	XX	X	X
Version:			
standard	00		
custom-made*	XX		
Language:			
polish		P	
english		E	
other		X	
Acceptance tests:			
without extra quality requirements			0
with an extra quality inspection certificate			1
acc. to customer's requirements*			X

*After agreeing with the manufacturer

Example of Order:

The code: **P19 - 00E0** means:

P19 – humidity and temperature transducer

00 – standard version

E – English language version

0 – without additional quality requirements.



LUMEL S.A.

ul. Słubicka 1, 65-127 Zielona Góra, Poland

Tel.: (48-68) 45 75 100

Fax: (48-68) 45 75 508

e-mail: lumel@lumel.com.pl

<http://www.lumel.com.pl>

Export Department:

Tel.: (48-68) 45 75 302

Fax: (48-68) 32 54 091

e-mail: export@lumel.com.pl